



OWNER'S MANUAL

ULTRAVISION™

OWNER'S MANUAL

Model PET24-7-913
Version 2024.a



Congratulations!

Congratulations on your new intelligent floor cleaner! UltraVision is now at your service. To see him at his best, please read the Quick Start Guide and this manual thoroughly.

Welcome to the bObsweep family and Happy Sweeping!

If you have any questions or concerns, feel free to contact our helpful support team at support@bobsweep.com or 1-888-549-8847.

Business Hours: Monday – Friday, 9 a.m. – 5 p.m. Pacific Time.

Table of Contents

1 General
Safety Instructions
Declaration of Conformity
Warranty
Contact Us

9 Getting Started
Who is UltraVision?
Navigating Difficult Obstacles

25 Mopping
Wet Mop Attachment

31 Manuel
D'utilisation
Franciase

3 Box Contents

4 Anatomy

- The bot
- Screen & Buttons
- Charging Station
- Dustbin
- Mop Attachment

11 First-Time Setup

- Install Side Brush
- Power UltraVision ON
- Set up Charging Station
- Charge UltraVision
- Download the bObsweep App
- Let your bot Sweep

18 Maintenance

- Charging Station
- Dustbin and Filters
- Brushes
- Sensors
- Front Wheel
- Battery

27 Troubleshooting

- Trouble messages
- Home Checkup Test

29 FAQs

67 End User License Agreement

Important Safety Instructions

- Power UltraVision OFF and remove him from a power source when you are not using him and before conducting maintenance.
- UltraVision is not intended for use by persons (including children) with reduced physical or mental capabilities, or lack of experience and knowledge, unless under the close supervision of a person responsible for their safety.
- Leaks from the battery cells can occur under extreme usage or temperature conditions. If the liquid gets on the skin, wash quickly with water. If the liquid gets into the eyes, flush them immediately with clean water for a minimum of 10 minutes, and seek medical attention.
- UltraVision is composed of electronic components that in rare and unintended cases can cause hazards of heating, fire, and other malfunctions. Furthermore, because UltraVision is capable of autonomous movement, his use poses the risk of collision with property, pets, and persons. Unintended removal of articles — such as small valuables, jewelry, or hair of persons or pets lying on the floor — may also occur.
- If UltraVision or his charging station has been damaged in any way, do not operate them. Contact our support team for further assistance.
- Do not handle UltraVision or his charging station with wet hands; use only on dry surfaces.
- Do not pull or carry the charging station by the cord, close a door on the cord, or pull the cord around sharp edges or corners. Keep the cord away from heated surfaces. To unplug the cord, grasp the plug, not the cord.
- Do not expose UltraVision's SLAM LiDAR to direct sun light or infrared light.
- Do not let UltraVision drop. The impact from a drop can damage the SLAM LiDAR.
- Do not look directly into the rotating transmitting part (laser) of the SLAM LiDAR.
- For your safety, do not insert tools, fingers, or other items into the rotating part of the SLAM LiDAR.
- Do not attempt to open the charging station. Repairs on the station should only be carried out by our qualified technicians.
- With the exception of the wet mop attachment, do not immerse any part of UltraVision into water or other liquids.
- Do not mutilate or incinerate the battery, as it will explode at high temperatures.
- Do not use UltraVision outdoors. And , do not store UltraVision in a car.
- Do not expose UltraVision or his charging station to temperatures higher than 113° F (45° C), moisture, or humidity.
- Do not dispose of your battery in fire. Old batteries should be recycled safely through your local recycler.
- Do not let UltraVision pick up anything that is burning or smoking, such as cigarettes, matches, or hot ashes.
- Do not use a broken or damaged power inlet/wire
- Do not open or handle UltraVision's charging station when plugged into the wall. Unplug first.

Declaration of Conformity

This device complies with Part 15 of the FCC rules. Operation is subject to the following two conditions: (1) this device may not cause harmful interference, and (2) this device must accept any interference received, including interference that may cause undesired operation. The manufacturer is not responsible for any radio or TV interference caused by unauthorized modifications or changes to this equipment. Such modifications or changes could void the user's authority to operate the equipment.

This equipment has been tested and found to comply with the limits for a Class B digital device, pursuant to part 15 of the FCC Rules. These limits are designed to provide reasonable protection against harmful interference in a residential installation. This equipment generates, uses, and can radiate radio frequency energy and, if not installed and used in accordance with the instructions, may cause harmful interference to radio communications. However, there is no guarantee that interference will not occur in a particular installation. If this equipment does cause harmful interference to radio or television reception, which can be determined by turning the equipment off and on, the user is encouraged to try to correct the interference by one or more of the following measures:

- Reorient or relocate the receiving antenna.
- Increase the separation between the equipment and receiver.
- Connect the equipment to an outlet on a circuit different from that to which the receiver is connected.
- Consult the dealer or an experienced radio/TV technician for help.

Warranty

Every UltraVision purchased from an authorized seller comes with our warranty coverage:

- 2-Year Standard Warranty
- 5-Year Subsidized Repair Plan
- Lifetime of Customer Service

To claim your warranty, register your bot at www.bobsweep.com/warranties.

Contact Us

If you have any questions or concerns, please contact our helpful support team at support@bobsweep.com or 1-888-549-8847.

Business Hours:

- Monday – Friday, 9 a.m. – 5 p.m. Pacific Time

Additional troubleshooting information and how-to guides can be found on the bObsweep app and at bobsweep.com/ultravision-support.

Box Contents



UltraVision™



Self-emptying
Charging Station



Charging Bed



Cleaning Tool



Side Brush (2)

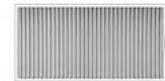

Filter



Mop Attachment



Microfiber Mop
Cloth (2)



Dust Bag

Anatomy

UltraVision

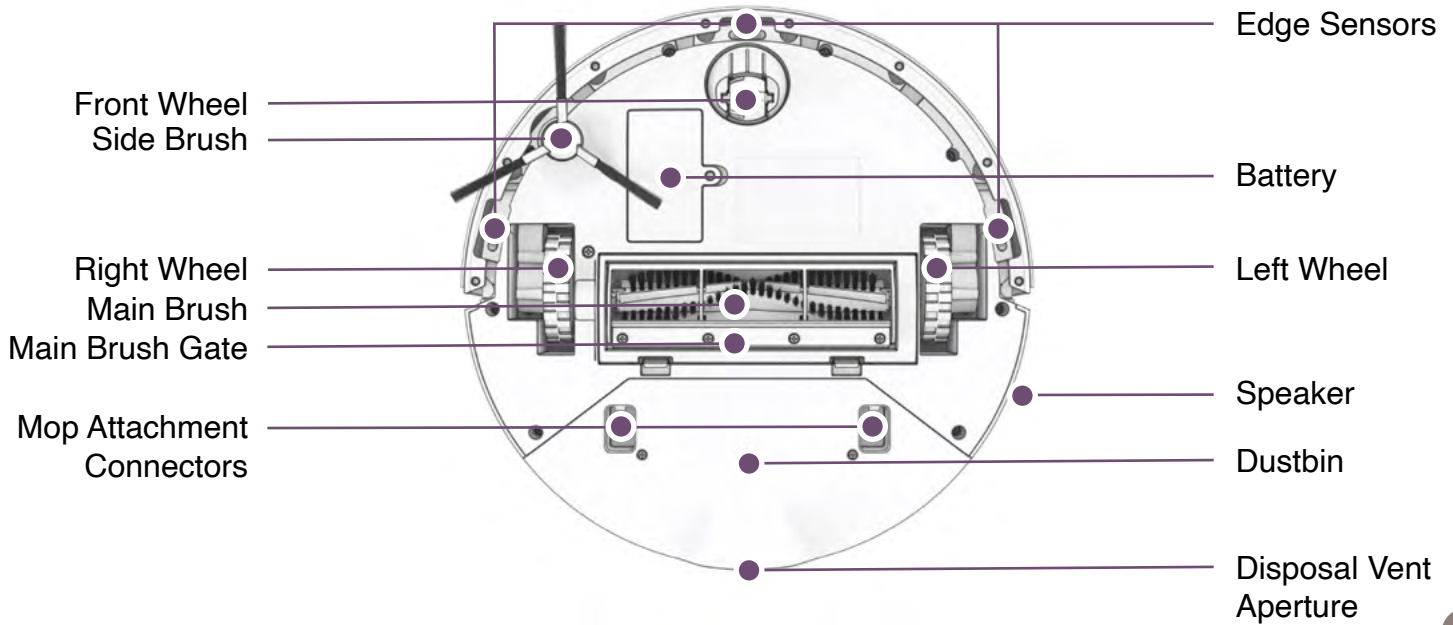
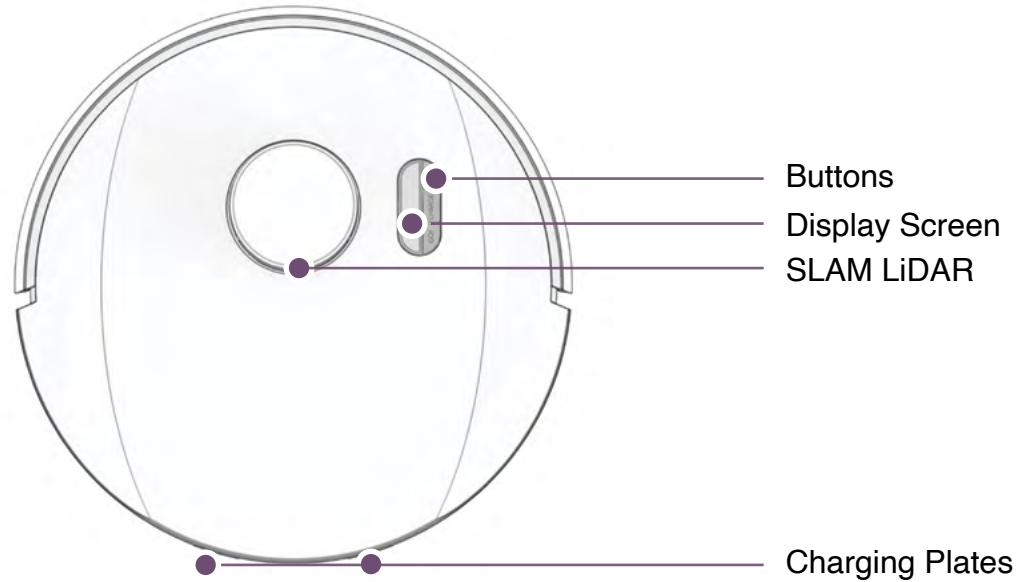

Anatomy

Display Screen & Buttons

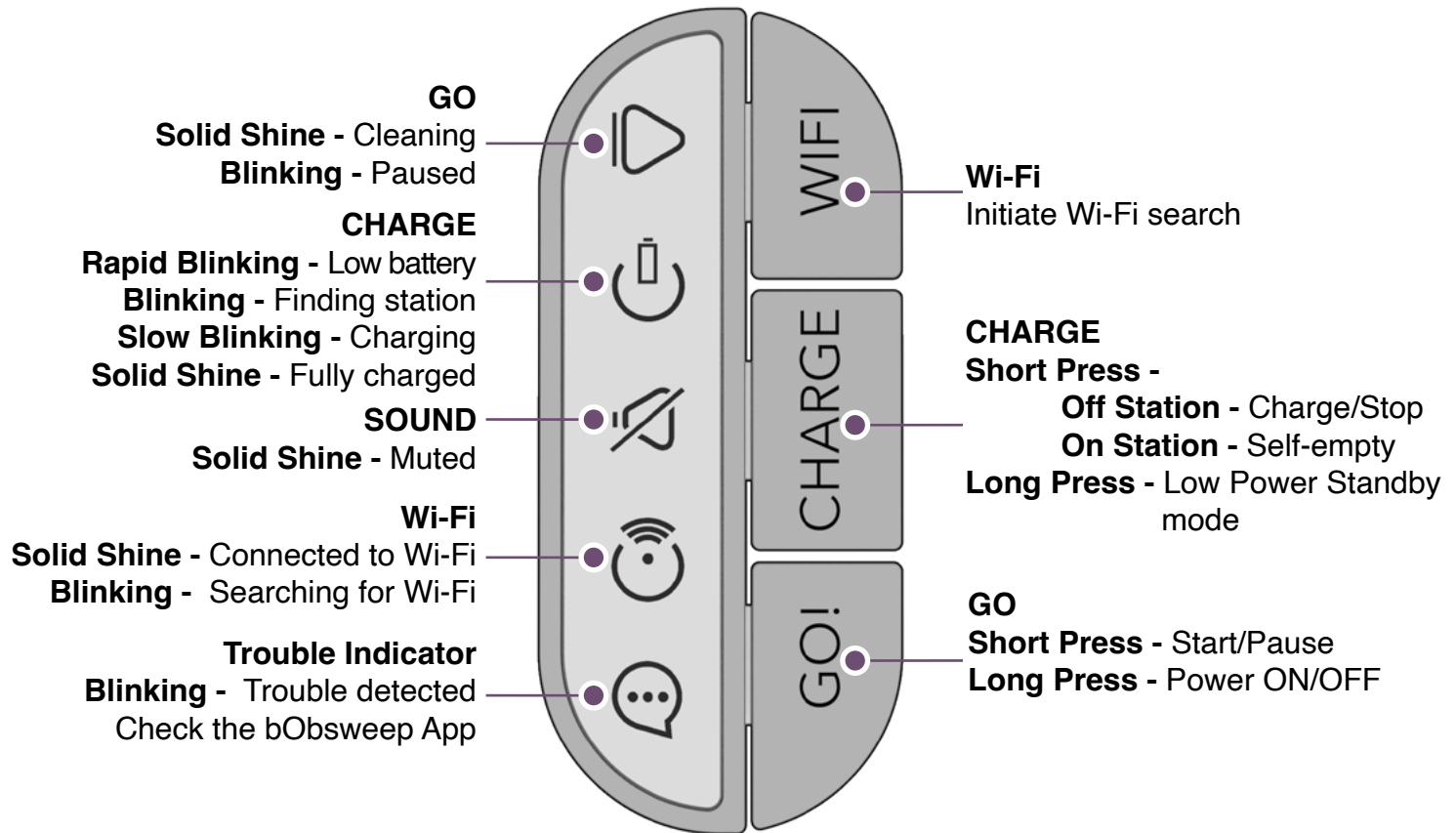

Anatomy

Self-emptying Charging Station

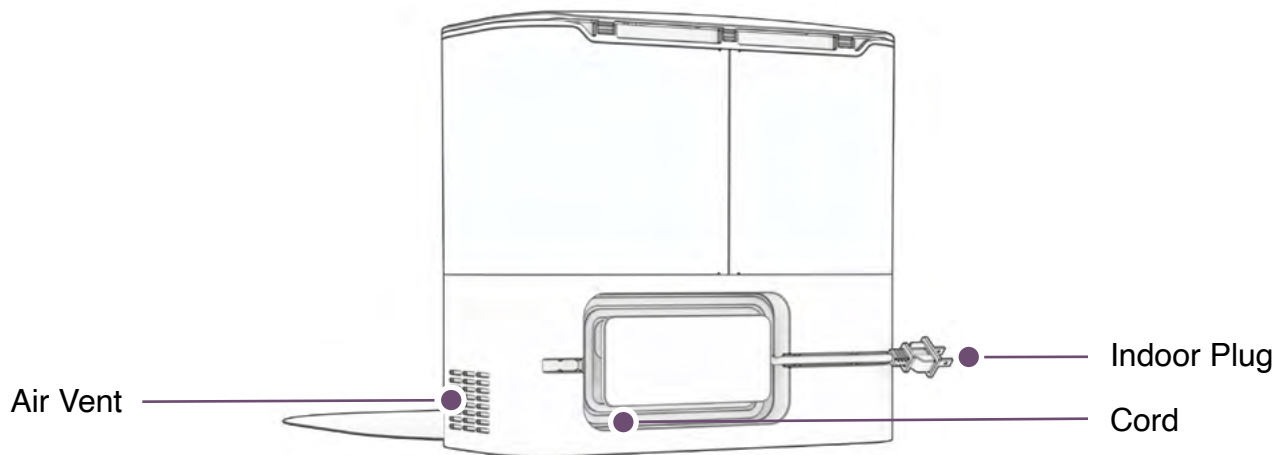
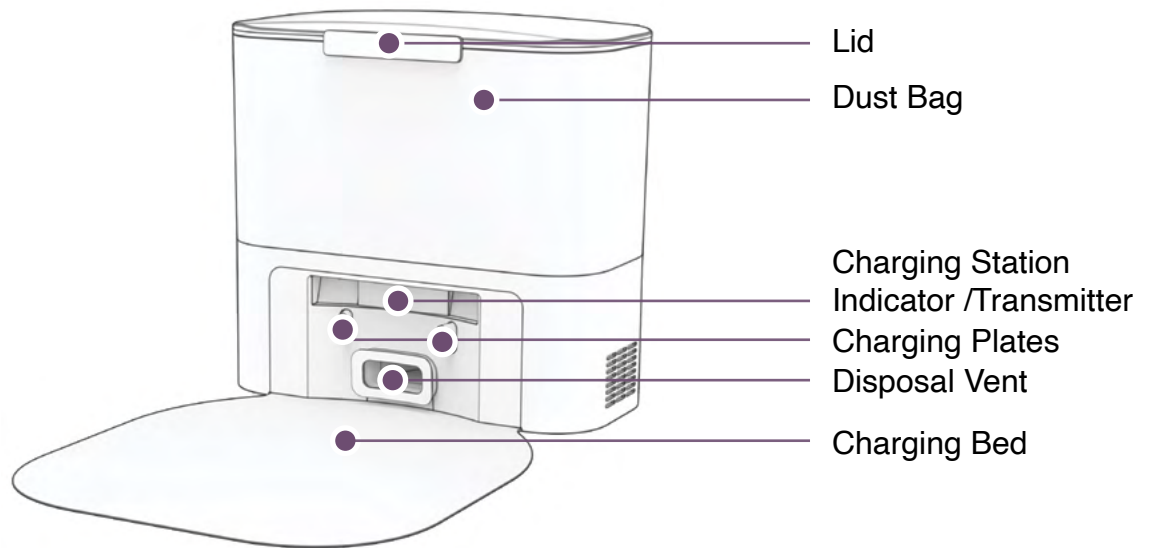

Self-emptying Charging Station

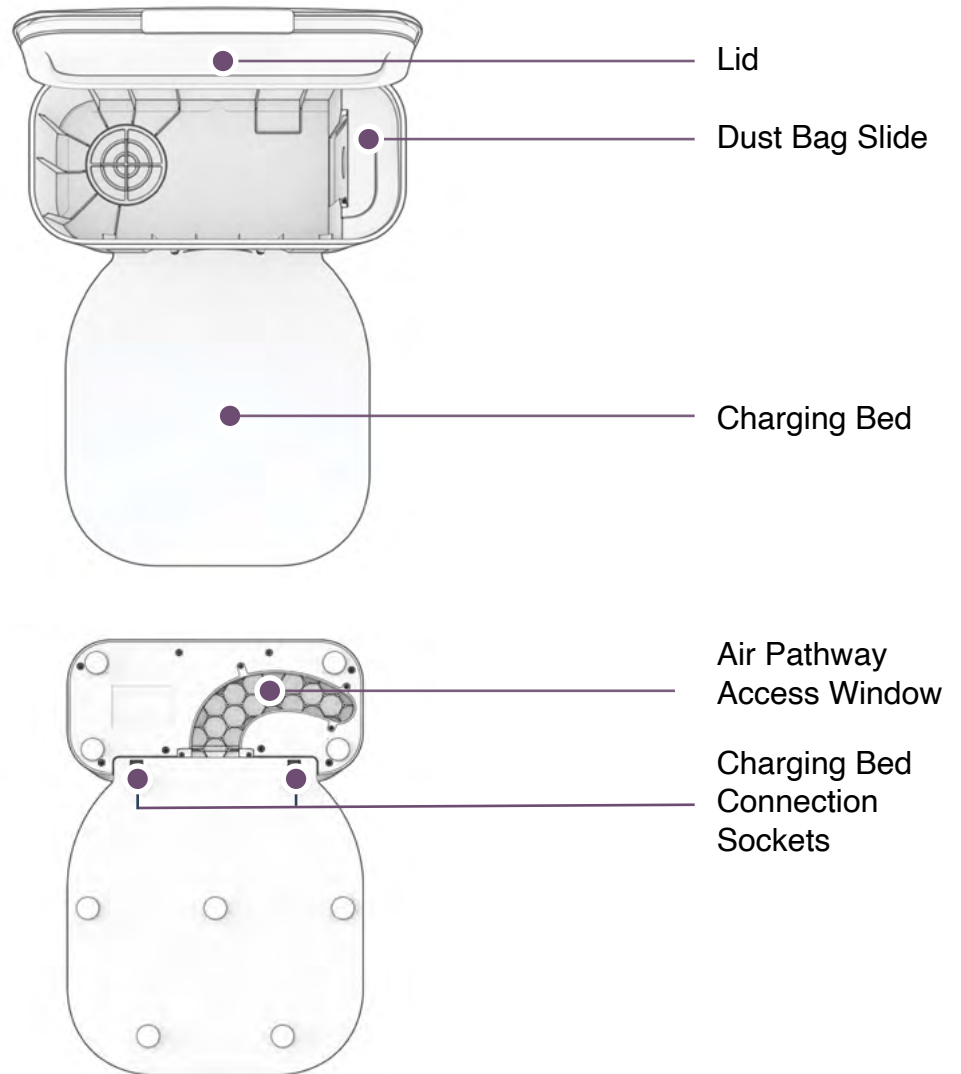

Dustbin & Mop Attachment

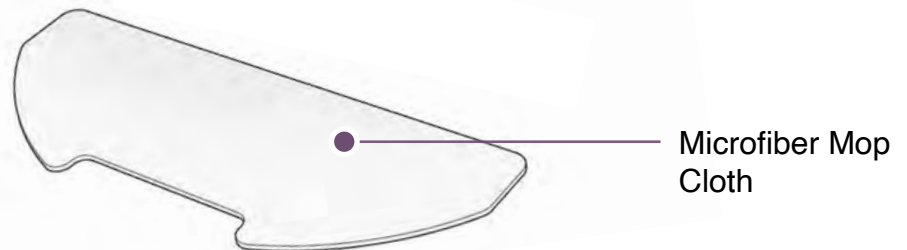
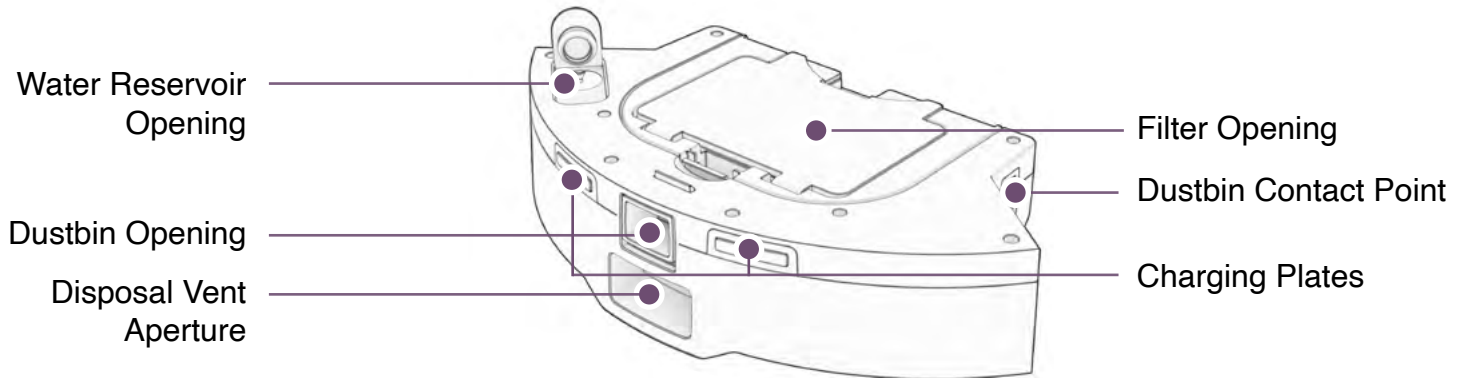

Getting Started

Who is UltraVision?

UltraVision is an autonomous robotic vacuum cleaner, at your service! Connect UltraVision to Wi-Fi and use the bObsweep app to create a customized cleaning plan. UltraVision will clean your home, your way.

How does UltraVision find his way around?

UltraVision uses laser vision, a network of sensors, and a state-of-the-art mapping and localizing technology to detect walls, furniture, and obstacles.

As UltraVision cleans, he simultaneously creates a map of the areas he is able to access and clean. Areas where furniture and small items are found are marked on the map. View the map by clicking the Map Icon on the bObsweep App, and customize it as desired. Using the map, and the app's customization criteria, UltraVision efficiently cleans your home over the course of a full cycle.

After cleaning, UltraVision returns to his station and empties his dustbin into his Charging Station's container. Forget about vacuuming and enjoy clean floors for weeks!

Learn about UltraVision's map features:



Watch UltraVision's how-to videos:

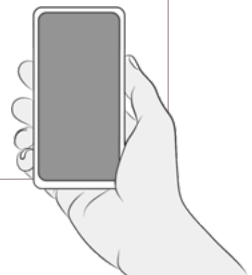

Navigating Difficult Obstacles

Unique Furniture

Specialty furniture, such as desk chairs with wheels or stools with circular bases, may confuse UltraVision momentarily; he may get stuck on a ledge for a few minutes, and then decide to clean somewhere else. As long as UltraVision is not displaying a trouble message, let him continue cleaning and finding his own way around. Take note of the areas that UltraVision finds most challenging, and, if possible, adjust furniture, or add NoSweep™ zones.

Dark-Colored Carpet

If UltraVision repeatedly backs up or displays a trouble message while cleaning dark carpets, deactivate the edge sensors.

To deactivate them, open the bObsweep app and disable “ edge detection ” under Cleaning Preferences in Settings .

Just remember that while UltraVision’s edge sensors are deactivated, **he will not be able to detect edges or stairs** and will fall off the edge if he gets close to one! Add NoSweep lines where the edge or stairs are to keep UltraVision safe.

Shag Carpet

UltraVision’s main brush is not designed to clean shag carpets or rugs with long fibers and fringes. If you’d like UltraVision to clean shag carpet or long-fibered rugs, you may remove his main brush and allow him to vacuum without it.

Mopping

Add NoMop zones to areas with rugs or carpets to keep UltraVision out of those areas while mopping.

UltraVision's First Clean

Install UltraVision's Side Brush

Install UltraVision's side brush to help him reach the corners and edges of rooms.

Parts You'll Need:



Side Brush

Before Starting

Remove protective pieces from UltraVision, his bumper, and charging station.



Place the side brush over the empty socket on UltraVision.

Press down to 'click' and lock in place.

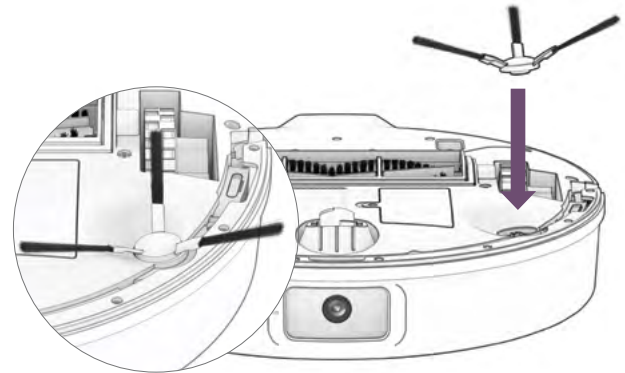

Important Note: The strength of side brush's connection can be increased by slightly rotating the screw in the center of the side brush socket counter-clockwise.

UltraVision's First Clean

Power UltraVision ON

Press and hold the GO button until the screen lights up.

Storing

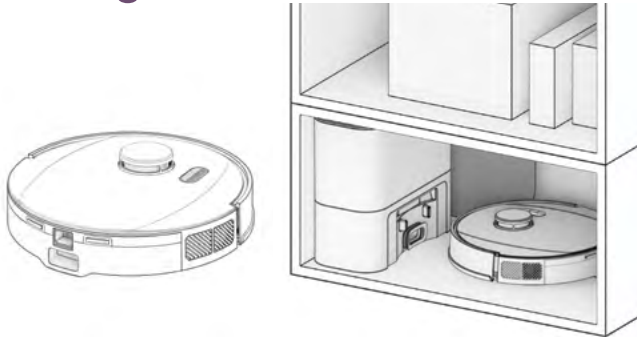

If you are not using UltraVision for an extended period of time (over a month), power him OFF, remove his battery, and unplug his charging station. Store everything in a dry room, away from direct sunlight or extreme temperature.

If you are not going to use UltraVision for a while, you can place him on Low Power Standby mode (LPS mode). To do so, place UltraVision on his charging station. Press and hold the CHARGE button on UltraVision for 5 seconds. You'll hear "low power mode", confirming UltraVision is in LPS mode. To exit this mode, press GO on UltraVision while he's on the charging station, or remove him from the station.



Important Note: In this mode, UltraVision is offline and the bObsweep App is not able to connect to UltraVision. Furthermore, any scheduled cleaning will be paused.

UltraVision's First Clean

Set up UltraVision's Self-emptying Charging Station

Bright sunlight, shiny surfaces, and reflective objects can interfere with UltraVision's docking signals. Set up UltraVision's station away from uncovered windows, mirrors, and shiny furniture or objects.

Parts You'll Need:



Self-emptying Charging Station



Charging bed

Positioning

UltraVision returns to his charging station after cleaning. To help UltraVision, place the charging station on a hard, flat surface, away from edges and stairs, with plenty of room around it.

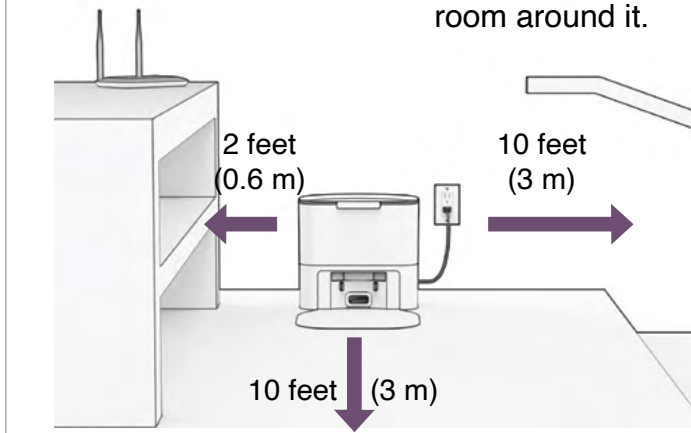

Place the charging station over the sockets on the charging bed. Place down to hold into place.

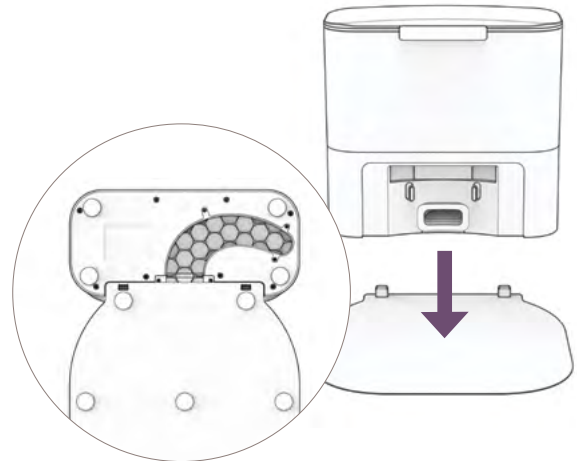

Quick Tips: The sockets on the charging bed fit into the charging station on its front.

Self-emptying Charging Station Indicator

When UltraVision finishes docking on his charging station, and there is no station error, the indicator light on the station turns off.



Light Status	Station Status	What to do
● Off	Powered OFF	Plug into the outlet.
● Solid Blue	Ready	Send UltraVision to charge / self-empty.
● Solid Red	Dust Bag not detected / Dust Bag's opening is closed.	Insert Dust Bag into the slide and push the tab all the way down to open and line up with the air pathway.
● Blinking Red	Congestion in air pathway.	<ul style="list-style-type: none"> Remove and open the dustbin to clean and remove heavy congestion. Clean the Disposal Vent Aperture on the back of the dustbin. Check the flap for free movement. Place UltraVision on the station and press 'Charge' to initiate a self-empty. <p>If the airpathway does not clear:</p> <ul style="list-style-type: none"> Unplug the station, turn the station around to open the Air Pathway Access Window and remove any congestion from the air pathway. Place UltraVision on the station again and press 'Charge' to initiate a self-empty.

UltraVision's First Clean

Charge UltraVision

Press the CHARGE button on UltraVision to send him to his charging station.

Parts You'll Need:



Self-emptying Charging Station

Charging Indicator



Low Battery:  blinks rapidly.

Finding Station:  blinks.

Charging:  blinks slowly.

Fully Charged:  shines white.

To charge UltraVision manually, place him on his charging bed with the metal nodes on his back resting against the plates on the station.

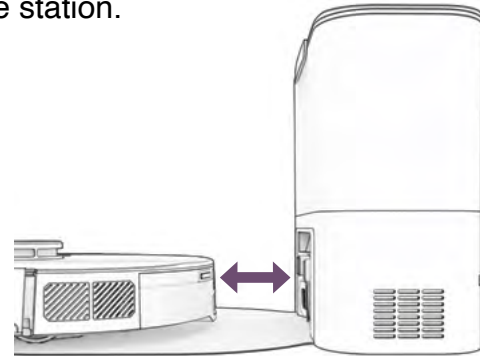

Quick Tip: UltraVision empties his bin each time he docks at the end of a cleaning session. Define how often UltraVision self-empties under “Cleaning Preferences” on the bObsweep App.

UltraVision's First Clean

Download the bObsweep App

Connect UltraVision to Wi-Fi to gain access to UltraVision's full suite of features and important software updates. Follow the instructions on the app to connect to Amazon Alexa or Google Home devices.

Items You'll Need:



Smart Phone



2.4GHz Wi-Fi Connection

Swift Mapping

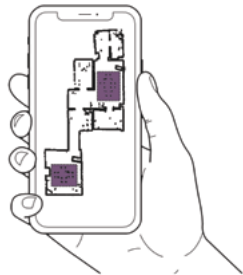

UltraVision maps the area at first glance. Choosing Swift Map makes UltraVision start a map-only run. UltraVision returns to his charging station after he explore and maps the entire floor. Leave all the doors open and remove clutter before initiating a Swift Map.

Open the bObsweep App, create your account, and follow instructions to connect your bot to Wi-Fi. Scan below for step by step instructions:

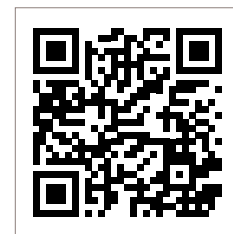

UltraVision's First Clean

Let UltraVision Sweep!

UltraVision is now ready to sweep! Clear away any clutter or wires and press the GO button.

Lifting & Moving

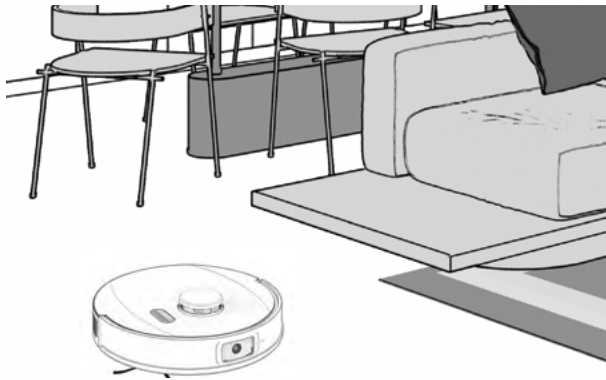

Do not pick UltraVision up while cleaning to avoid distorting his map.

It's best not to change the location of UltraVision's charging station after he's done mapping the house.

Equipped with Room-to-Room™ cleaning technology, UltraVision automatically explores and cleans your home, avoiding furniture and obstacles along his path. For best results, remove clutter and small objects.



Maintenance

For Best Performance

To maximize UltraVision's efficiency, it is best to keep his brushes, filters, and sensors clean.

Part	Maintenance Frequency	Replacement Frequency
Charging Station	Monthly	
Dustbin	Monthly	
Filter	Monthly	Every 6 months
Brushes	Weekly	Every 12 months
Sensors	Weekly	
Front Wheel	Weekly	
Battery		Every 24 to 36 months

Quick Tips: Clear debris out of nooks and crannies around the brushes and wheels.
Use tweezers to remove congestion from the brush ends and main and side brush compartments on UltraVision.
Use scissors or the included cleaning tool to cut hair wrapped around the brushes.

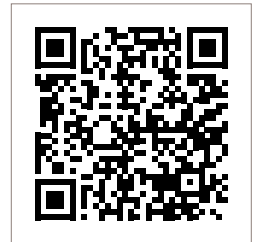

Maintenance

Dust Bag

1. Open the lid.

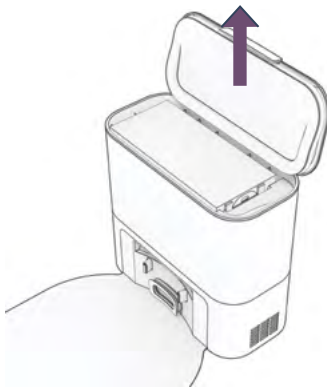

2. Pull up the tab to close the dust bag's opening. Lift to remove the full dust bag and discard.

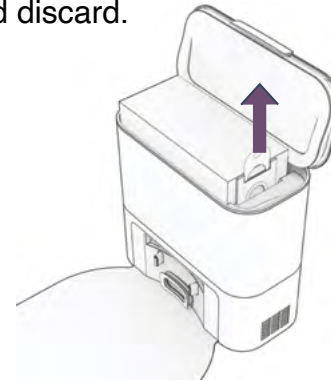

3. Place the new dust bag, sliding the card into place completely. Slide the opening tab all the way down.

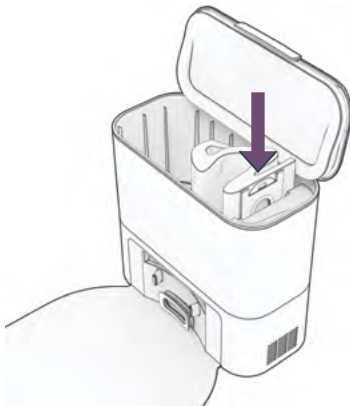

4. Close the lid.



Self-emptying Charging Station

Before cleaning the charging station, unplug it.

1. Wipe the charging nodes (contact points).



2. Wipe the transmitter window clean, making sure it is not blocked or covered.



3. Remove the dustbag and clean the dustbag container from debris buildups or any blockage for free flow of air.



4. Unplug the station. Inspect the disposal vent and air pathway. Clean and remove any congestion.

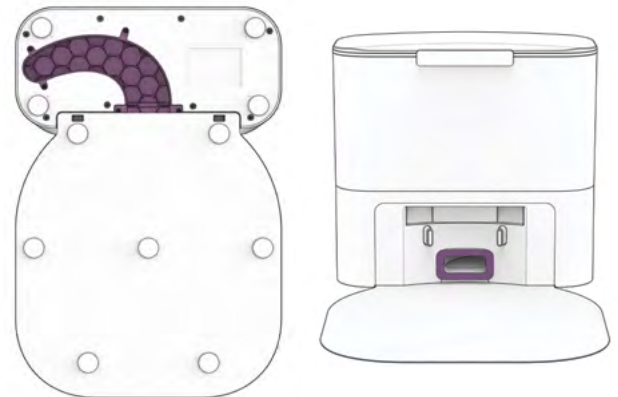

Maintenance

Brushes

1. Pull up to remove the side brush.

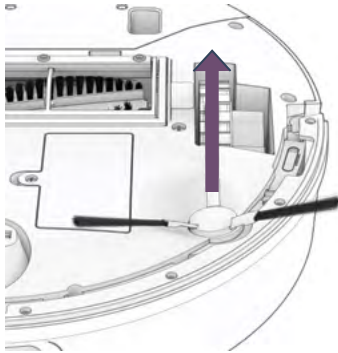

2. Remove debris from the side brush and its socket.

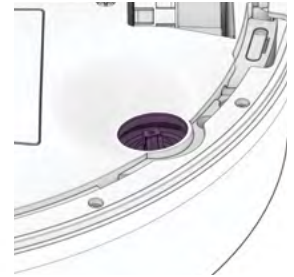

3. Pinch the tabs on the main brush gate and lift.

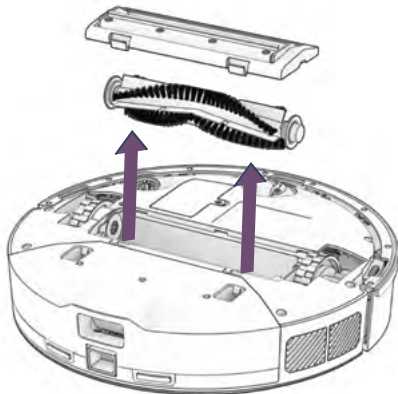

4. Clean the main brush and all its components, including the brush gate and brush compartment.

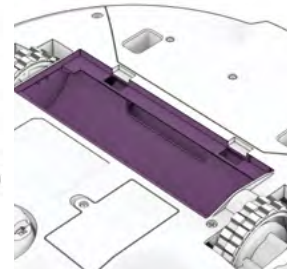

Maintenance

Sensors

Use a soft cotton cloth to wipe the sensors.

1. Wipe the camera, edge sensors, and obstacle sensors.

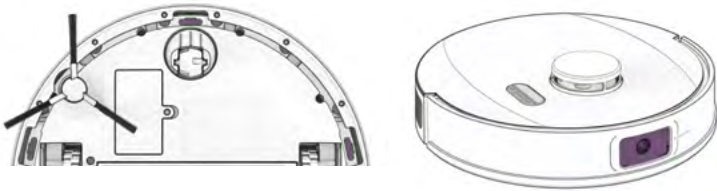

2. Wipe the charging nodes on UltraVision and his station.

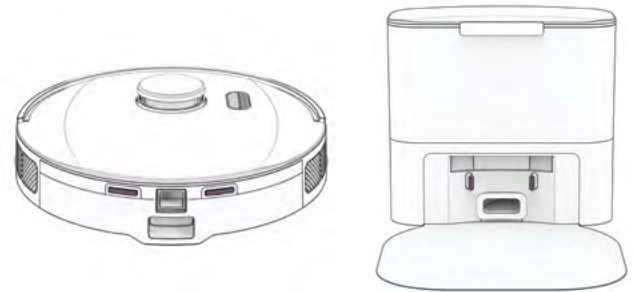

3. Wipe the metal connectors on the dustbin and wet mop attachment.

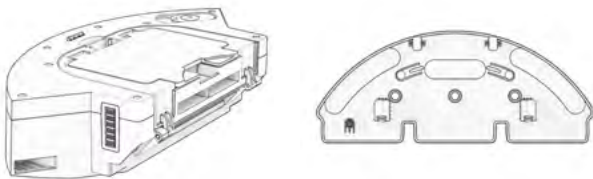

4. Wipe the top and the area around the SLAM LiDAR.

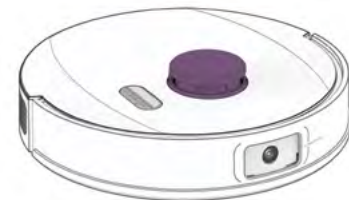

Important Note: UltraVision's SLAM LiDAR is a sensitive sensor. Do not apply force, insert objects, or adjust the SLAM LiDAR. Do not sit on UltraVision or place items on top of him.

Front Wheel

1. Using a flat head screwdriver for leverage, grip the wheel firmly and pull.



2. Once the wheel is removed, use the screwdriver to pry out the wheel assembly.

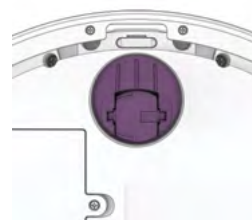

3. Clean the wheel and all its components, including the assembly and wheel socket.

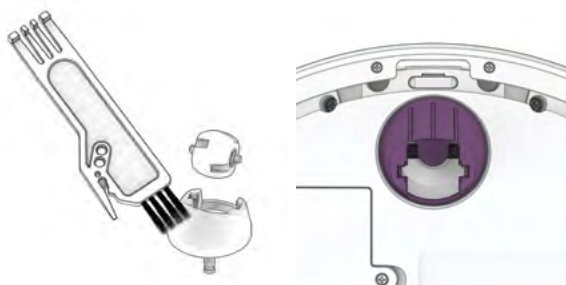

4. Replace both parts when done. Push down to lock them into place.

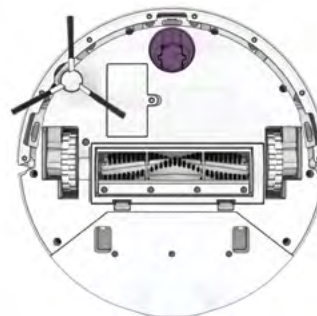

Maintenance

Battery

Power OFF UltraVision before replacing the battery. Press and hold the GO button.

1. Use a Phillips head screwdriver to open the battery compartment.

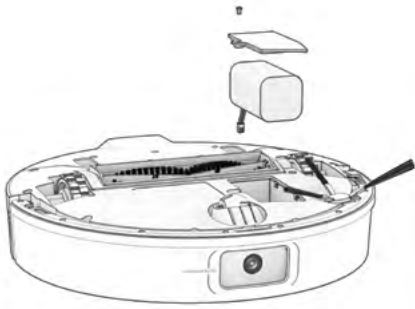

2. Unplug the old battery and plug in your new one.



3. Slide the new battery into UltraVision.

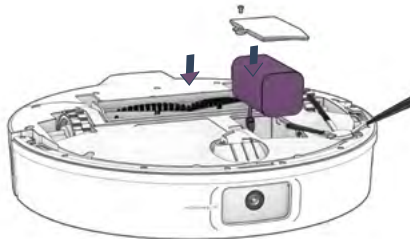

Important Note: High power mode exponentially increases UltraVision's battery use. Use low power mode to reduce power usage on UltraVision.

Mopping

UltraVision's First Mop

Open the App and draw NoMop zones over carpeted areas and rugs on the map. To set up UltraVision's mop:

1. Remove the dustbin.

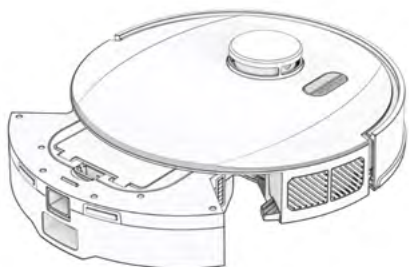

2. Open the reservoir tab and fill it with water. Use distilled water in hard water areas.

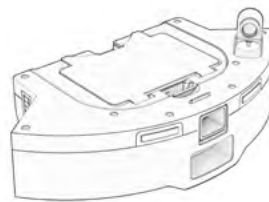

3. Align the mop attachment connectors with the dustbin's and press to lock in place.

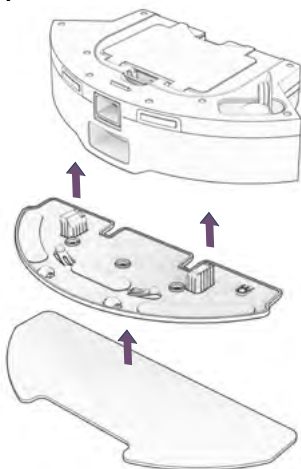

4. Replace the dustbin.

Note: With the mop attachment connected, UltraVision will not enter any NoMop zones added to his map.

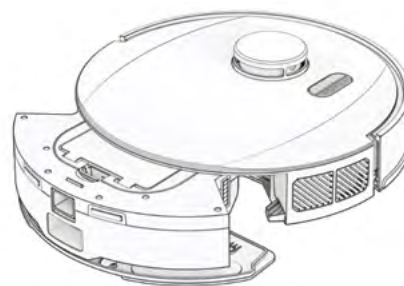

Mopping

Mop Attachment Maintenance

The reservoir should be drained after use to avoid possible water damage.

1. Remove the mop attachment.

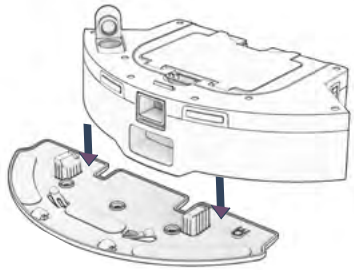

2. Pull open the tab and empty the reservoir.

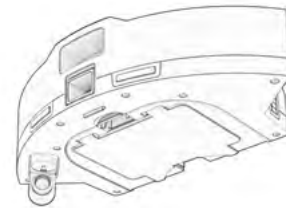

3. Wash the mopping cloth. Air-dry all parts when done.

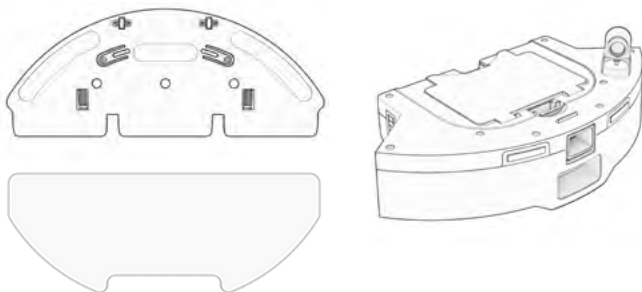

4. Learn more about UltraVision's mop feature:



Troubleshooting

Whenever UltraVision runs into trouble, he will stop and his trouble indicator will blink. Check the bObsweep app for trouble details.

Trouble	Solution
Battery	Low or disconnected battery. Check connection. Reset, and charge UltraVision.
Left/Right Wheel	Left/Right wheel is jammed. Check for obstruction and clean.
Main/Side Brush	Main/side brush is jammed. Remove and clean.
Camera	Camera component error. Reset UltraVision (Power OFF and back ON).
Dustbin	Dustbin is disconnected or contact points are dirty. Clean contact points and reinsert. Or, the vacuum Motor is jammed. Check for obstruction and clean.
Mop Attachment	UltraVision is trying to mop but the mop attachment is disconnected or contact points are dirty. Check for obstruction and clean.
Edge Sensors	UltraVision is stuck near a cliff, is off ground, or the edge sensors are dirty. Move UltraVision to safety, and clean the edge sensors.
Bumper	Bumper is dirty or jammed. Wipe around the bumper; remove any obstruction.
LiDAR Bumper	SLAM LiDAR's bumper is jammed. Check for obstruction and clean.
LiDAR	SLAM LiDAR is not clean/lost visibility. Clean the SLAM LiDAR and move UltraVision away from mirrors/metallic surfaces/walls and to the center of the room.
Charging Station	Can't locate the charging station. Replug the charging station and charge UltraVision.
User Interface	UltraVision's UI/USB port is not responding. Reset UltraVision & ensure the USB port is empty.
Electronic	Electronic component error. Reset UltraVision (Power OFF and back ON).
Stuck	UltraVision is stuck. Clear away obstacles/clutter/wires & reset UltraVision.
Navigation	UltraVision is not able to navigate. Clear away any clutter/wires & reset UltraVision.
Localization	UltraVision can't self locate on map. Check map accuracy/erase map for remapping.
Settings	Current room settings don't match UltraVision's. Change map settings/schedules.

Home Checkup Test

If UltraVision is not performing as well as he should, you can diagnose the problem with a simple home checkup test.

Putting UltraVision in/out of checkup mode

To put UltraVision in Checkup mode:

Press and hold the “GO” “CHARGE” and “WI-FI” buttons simultaneously for a few seconds until the bot says: “Home Checkup Mode Activated”. In this mode, UltraVision’s LiDAR sensor rotates.

To exit the Checkup mode:

Press the “GO” “CHARGE” and “WI-FI” buttons together again. You’ll hear “Exiting Home Checkup Mode” and UltraVision’s LiDAR sensor stops rotating.

Important Notes:

- During the test, if UltraVision’s left idle for over a minute, he’ll automatically exit the Home Checkup Test.
- To move among Steps in the Checkup test, press the Wi-Fi button.
- To start / stop the tests in each Step, press the GO button until you hear “Begin Test” and “Stop Test”. Always stop a test before moving to the next step.

Step	Part(s) Tested	Description
1	Battery	After a full charge, test UltraVision’s battery.
2	Edge Sensors	Test edge sensors individually.
3	Charging Station	Test charging sensors individually.
4	Bumpers, Wi-Fi, and Camera	Test the Wi-Fi module, touch sensors, and camera.
5	Motors (wheels, brushes, vacuum, mop)	Test each of UltraVision’s motors individually.
6	SLAM LiDAR, Charging and Self-empty	Test UltraVision’s SLAM LiDAR, charging contact points, and self-empty function.
7	Hard Resetting UltraVision	Factory reset UltraVision and erase all data.

For a step-by-step video guide of Home Checkup Test, visit: bobsweep.com/UltraVision-support.

FAQs

UltraVision won't turn on no matter what I do.

If UltraVision is not responding to his buttons, then his battery has likely drained too low for him to operate. Place UltraVision on his charging station and allow him to fully charge. **When placing him on the station, ensure the dustbin is fully latched, and there's perfect alignment between the charging nodes on the back of UltraVision and his charging station's.**

UltraVision runs out of battery before he's finished mapping.

Use the 'Swift Map' feature on the bObsweep app to ask UltraVision to map the floor without cleaning it. In this mode, UltraVision explores and maps the house, then returns to his charging station without cleaning it. If the floor is too large for UltraVision to fully clean in one charge, toggle on Auto-resume under Settings > Cleaning Preferences on the bObsweep app, and UltraVision will pickup where he left off after recharging.

UltraVision's not picking up as much as he used to.

UltraVision will have trouble cleaning if his dustbin is clogged, or his main brush is clogged or tangled with hair. Remove UltraVision's main brush and clean it thoroughly from end to end. Remove and open the dustbin, and remove any large debris from UltraVision's dustbin container to ensure smooth flow of air.

UltraVision is not self-emptying and the indicator on the station is flashing red.

By default, every time UltraVision docks, a loud vacuuming process empties his dustbin into his station's disposable dust bag. You can change the frequency using the bObsweep App. If UltraVision's dustbin gets too packed, or if the station's air passage is clogged, contents cannot be vacuumed out. Remove and open the dustbin and dump its contents. Unplug the station and open the air passage to remove anything clogging it.

UltraVision's having trouble finding his station.

Make sure UltraVision's charging bed is installed. You may need to relocate UltraVision's station to a more accessible area. Make sure the station is placed in a centralized area, on a hard, flat surface away from stairs or edges, direct sunlight, mirrors or reflective surfaces, and with plenty of open space around it. Then, erase the old map and let UltraVision remap the house from his new station.

Can I pick UltraVision up?

Picking up and moving UltraVision during a cleaning session is not recommended, as it can affect his current cleaning cycle/map. Furthermore, it's best not to relocate UltraVision's charging station once he has mapped his environment. If you have to relocate the station, erase the old map and let UltraVision map the house again.

FAQs

Can't connect UltraVision to Wi-Fi.

You can connect UltraVision to a 2.4GHz Wi-Fi after he's fully charged. To do so, turn ON 'Location Services' and 'Bluetooth' on your phone settings. Also allow 'Local Network' access and turn off 'Wi-Fi Calling' on your phone. Write down your 2.4GHz Wi-Fi network and its password (note that they are case sensitive). Bring UltraVision and your phone close to your modem or router and be sure to select the correct model name 'UltraVision' from the list of bots.

Can I make changes to or delete the map UltraVision made?

Yes. UltraVision's map is fully customizable and editable. Review the map, and make any modification you wish. For step-by-step instructions, visit: bobsweep.com/UltraVision-support.

Can UltraVision clean my multi-floor house?

Yes. UltraVision can save up to 3 floor maps. For step-by-step instructions on how to save maps, visit: bobsweep.com/UltraVision-support.

How can I diagnose UltraVision's exact problem?

You can check UltraVision's health through a Home Checkup Test. For more information on the test, visit: bobsweep.com/UltraVision-support.

UltraVision stopped cleaning and the trouble indicator is flashing.

When UltraVision is in trouble and needs your help, he will stop and the trouble indicator blinks. Open the bObsweep app and find the trouble details at the top of the Control page.

UltraVision is Offline.

UltraVision may be hibernating or is powered OFF and disconnected himself from Wi-Fi. To bring him back online, place him on the charging station and let him charge and power ON. For more information, visit: bobsweep.com/UltraVision-support.

UltraVision's getting stuck.

If there are areas of repeat problem in the house that UltraVision gets stuck under or stops on, draw NoSweep zones over them on the map to keep UltraVision out of trouble. For step-by-step instructions on how to draw/edit/save/delete NoSweep areas, visit: bobsweep.com/UltraVision-support.

Does UltraVision work with Google and Alexa devices?

Yes! UltraVision can be connected to Google Home and Alexa apps / devices. For more information, visit: bobsweep.com/UltraVision-support.

ULTRAVISION™

MANUEL D'UTILISATION

Model PET24-7-913
Version 2024.c



Félicitations!

Félicitations pour votre nouvel aspirateur de sol intelligent ! Ultra-Vision est maintenant à votre service. Pour que UltraVision donne le meilleur de lui-même, lisez attentivement le guide de démarrage rapide et le présent manuel.

Bienvenue dans la famille bObsweep et bon nettoyage !

Si vous avez des questions ou des préoccupations, n'hésitez pas à contacter notre équipe d'assistance à support@bobsweep.com ou au 1-888-549- 8847. Heures d'ouverture : Du lundi au vendredi, de 9 h à 17 h, heure du Pacifique.

Table des Matières

37 Généralités
Consignes de sécurité
Déclaration de
conformité
Garantie
Nous contacter

45 Bien commencé
Qui est UltraVision ?
Franchir des obstacles
difficiles

61 Accessoires
Netoyage humide

67 End User
License
Agreement

39 Contenu de la Boîte

47 Premier nettoyage

- Installer la brosse latérale
- Allumer UltraVision
- Installer la station de charge
- Charger UltraVision
- Télécharger l'app bObsweep
- Laisser UltraVision balayer

63 Dépannage

- Messages d'erreur
- Test de contrôle check-up

40 Anatomie

- UltraVision
- Écran et boutons
- Station de charge
- Bac à poussière et accessoire a nettoyage

54 Maintenance

- La Station et Poubelle
- Filtres
- Brosses
- Capteurs
- Roue Avant
- Batterie

65 FAQs

Consignes de sécurité importantes

- Mettez UltraVision hors tension et retirez-le de la source d'alimentation lorsque vous ne l'utilisez pas et avant d'effectuer des opérations de maintenance.
- UltraVision n'est pas destiné à être utilisé par des personnes (y compris des enfants) dont les capacités physiques ou mentales sont réduites, ou qui manquent d'expérience et de connaissances, sauf sous la surveillance vigilante d'une personne responsable de leur sécurité.
- Des fuites des cellules de la batterie peuvent se produire dans des conditions d'utilisation ou de température extrêmes. Si le liquide entre en contact avec la peau, lavez-la rapidement à l'eau. Si le liquide entre en contact avec les yeux, les rincer immédiatement à l'eau claire pendant au moins 10 minutes et consulter un médecin.
- UltraVision est composé d'éléments électroniques qui, dans des cas rares et involontaires, peuvent entraîner des risques de surchauffe, d'incendie et d'autres dysfonctionnements. En outre, UltraVision étant capable de se déplacer de manière autonome, son utilisation présente un risque de collision avec des biens, des animaux domestiques et des personnes. Le retrait involontaire d'articles - tels que de petits objets de valeur, des bijoux ou des poils de personnes ou d'animaux domestiques posés sur le sol - peut également se produire.
- Si UltraVision ou sa station de recharge ont été endommagés de quelque manière que ce soit, ne les utilisez pas. Contactez notre équipe d'assistance pour obtenir de l'aide.
- Ne manipulez pas UltraVision ou sa station de recharge avec des mains mouillées ; utilisez-les uniquement sur des surfaces sèches.
- Ne pas tirer ou porter la station de recharge par le câble, ne pas fermer une porte sur le câble et ne pas faire passer le câble par des arêtes ou des coins tranchants. Tenir le câble à l'écart des surfaces chauffées. Pour débrancher le câble, saisissez la fiche et non le câble.
- Ne pas exposer le SLAM LiDAR de UltraVision à la lumière directe du soleil ou à la lumière infrarouge.
- Ne laissez pas tomber UltraVision. L'impact d'une chute peut endommager le SLAM LiDAR.
- Ne regardez pas directement la partie émettrice rotative (laser) du SLAM LiDAR.
- Pour votre sécurité, n'insérez pas d'outils, de doigts ou d'autres objets dans la partie rotative du SLAM LiDAR.
- N'essayez pas d'ouvrir la station de recharge. Les réparations de la station ne doivent être effectuées que par nos techniciens qualifiés.
- À l'exception de l'accessoire pour nettoyage humide, n'immergez aucune partie de UltraVision dans l'eau ou dans d'autres liquides.
- Ne pas mutiler ou incinérer la batterie, car elle explose à haute température.
- N'utilisez pas UltraVision à l'extérieur.
- Ne pas stocker UltraVision dans une voiture.
- N'exposez pas UltraVision ou sa station de charge à des températures supérieures à 45°C, à l'humidité.
- Ne jetez pas votre batterie au feu. Les anciennes batteries doivent être recyclées en toute sécurité par votre recycleur local.
- Ne laissez pas UltraVision ramasser des objets brûlants ou fumants, tels que des cigarettes, des allumettes ou des cendres chaudes.
- N'utilisez pas d'entrée/fil électrique cassé ou endommagé.
- N'ouvrez pas et ne manipulez pas la station de recharge de UltraVision lorsqu'elle est branchée au mur. Débranchez-la d'abord.

Déclaration de Conformité

Cet appareil est conforme à la partie 15 des règles de la FCC. Son fonctionnement est soumis aux deux conditions suivantes :

(1) cet appareil ne doit pas causer d'interférences nuisibles, et (2) cet appareil doit accepter toute interférence reçue, y compris les interférences susceptibles de provoquer un fonctionnement indésirable. Le fabricant n'est pas responsable des interférences radio ou TV causées par des modifications ou des changements non autorisés apportés à cet équipement. De telles modifications ou changements pourraient annuler le droit de l'utilisateur à faire fonctionner l'équipement.

Cet équipement a été testé et déclaré conforme aux limites imposées aux appareils numériques de classe B, conformément à la partie 15 des règles de la FCC. Ces limites sont conçues pour fournir une protection raisonnable contre les interférences nuisibles dans une installation résidentielle. Cet équipement génère, utilise et peut émettre des fréquences radio et, s'il n'est pas installé et utilisé conformément aux instructions, peut causer des interférences nuisibles aux communications radio. Cependant, il n'y a aucune garantie que des interférences ne se produiront pas dans une installation particulière. Si cet équipement provoque des interférences nuisibles à la réception de la radio ou de la télévision, ce qui peut être déterminé en éteignant et en rallumant l'équipement, l'utilisateur est encouragé à essayer de corriger les interférences par une ou plusieurs des mesures suivantes :

- Réorienter ou déplacer l'antenne de réception.
- Augmenter la distance entre l'appareil et le récepteur.
- Brancher l'appareil sur une prise de courant située sur un circuit différent de celui sur lequel le récepteur est branché.
- Consulter le revendeur ou un technicien radio/TV expérimenté pour obtenir de l'aide.

Garantie

Chaque UltraVision acheté auprès d'un vendeur agréé est couvert par notre garantie:

- Garantie standard de 2 ans
- Plan de réparation subventionné de 5 ans
- Service clientèle à vie

Pour bénéficier de la garantie, enregistrez votre robot à l'adresse suivante:
www.bobsweep.com/warranties.

Nous Contacté

Si vous avez des questions ou des préoccupations, veuillez contacter notre équipe d'assistance à l'adresse suivante:

support@bobsweep.com or 1-888-549-8847.

Heures d'ouverture :

- Du lundi au vendredi, de 9 heures à 17 heures (heure du Pacifique)

Des informations de dépannage supplémentaires et des guides pratiques sont disponibles sur l'application bObsweep et sur le site:
www.bobsweep.com/ultravision-support.

Contenu de la Boîte



UltraVision™



Station de recharge
auto-vidieuse



Lit de charge



Brosse de
nettoyage



Brosse latérale
(2)

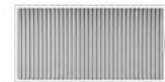

Filtre



Accessoire de
nettoyage



Serpillère en
microfibre (2)



Sac à poussière

Anatomie

UltraVision

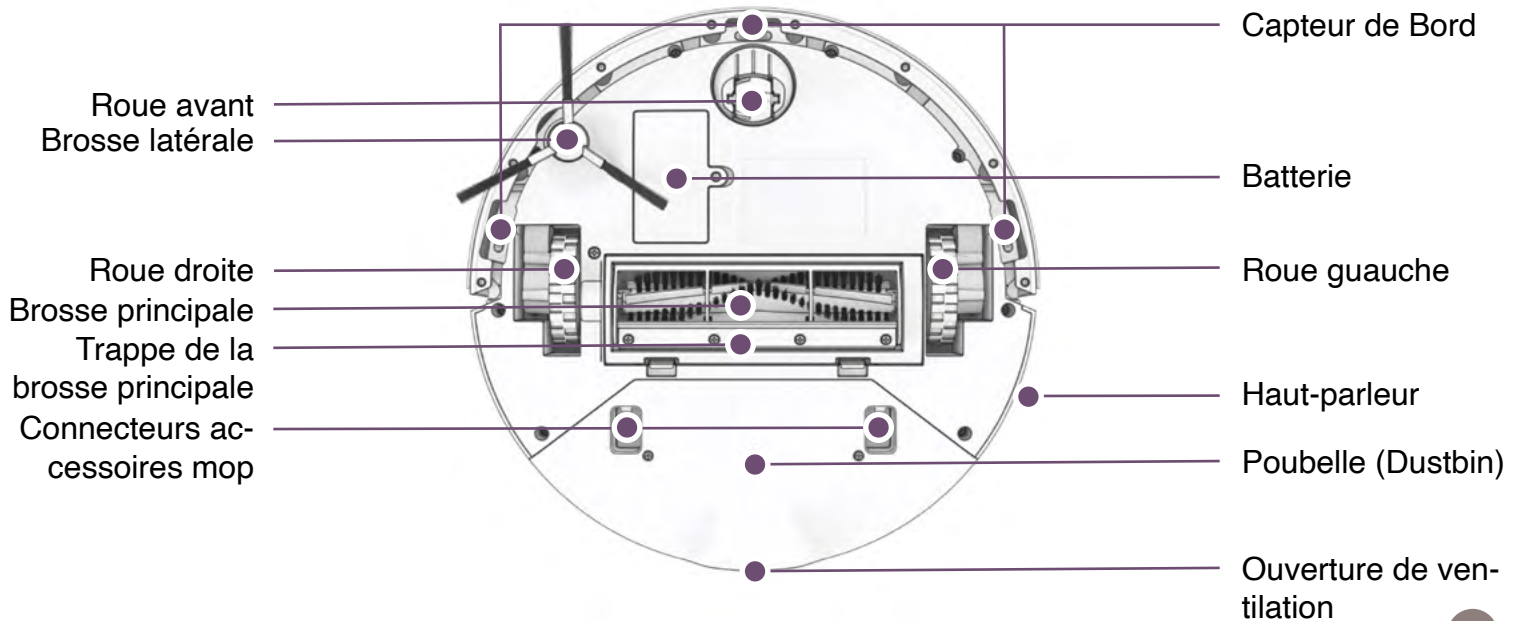
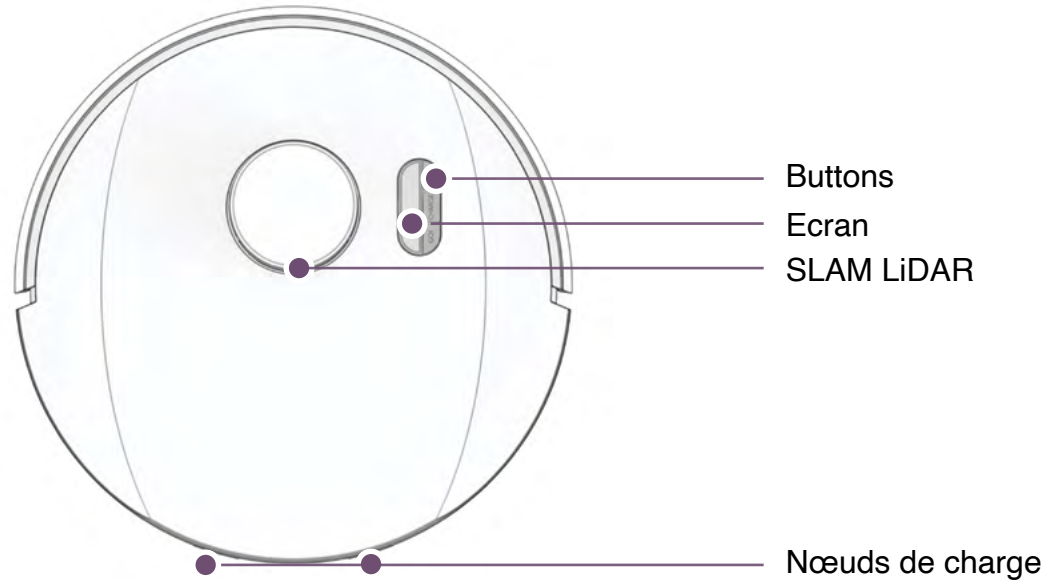

Écran d'affichage & boutons

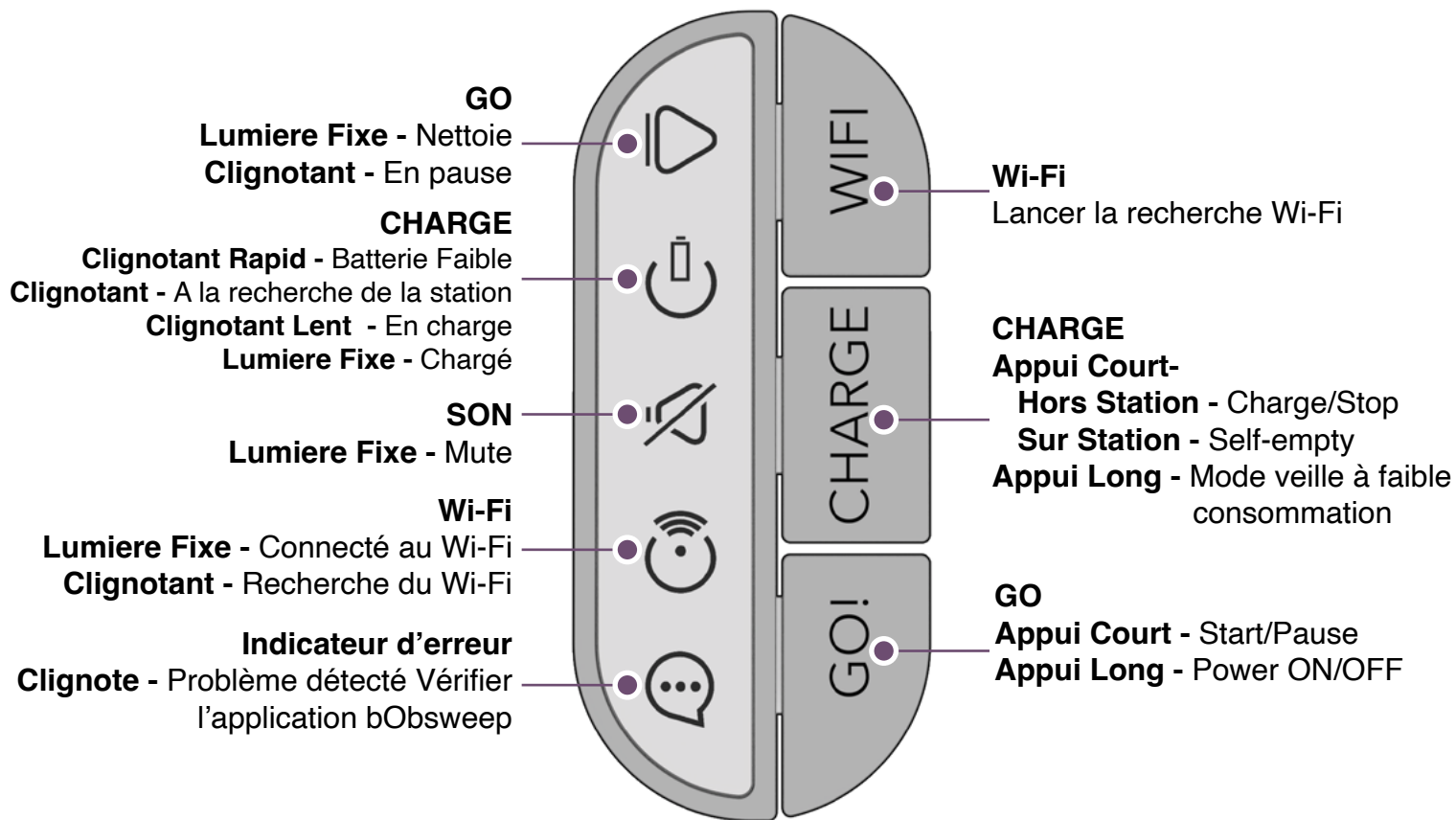

Station de recharge et d'auto-vidage

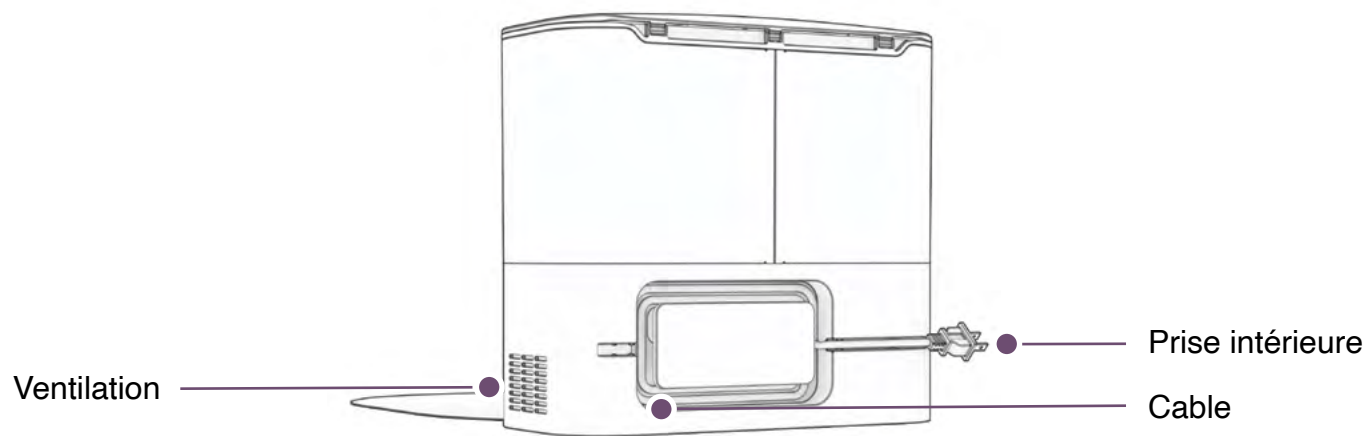
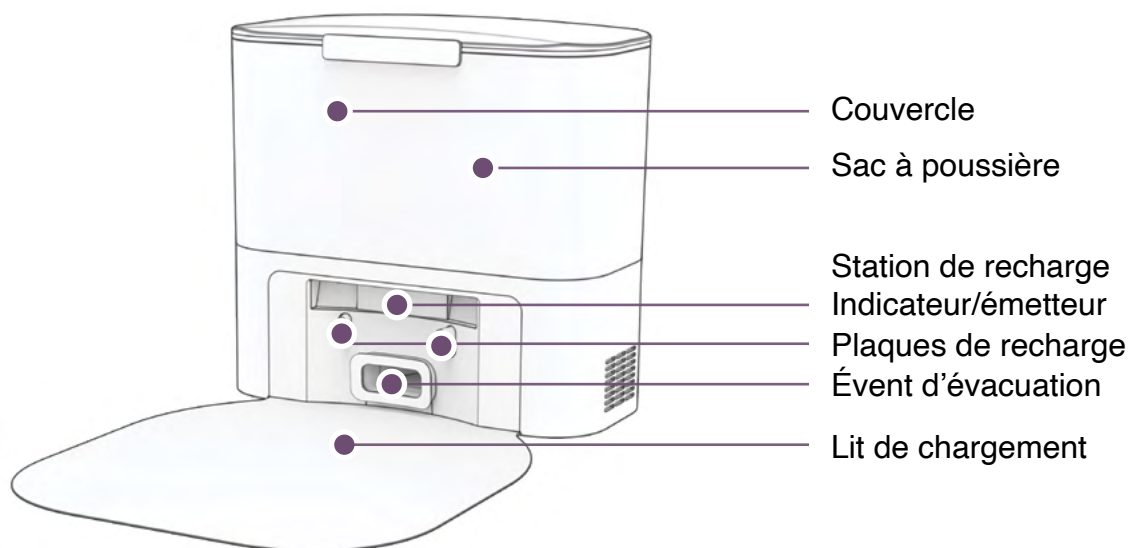

Station de recharge & d'autovidage

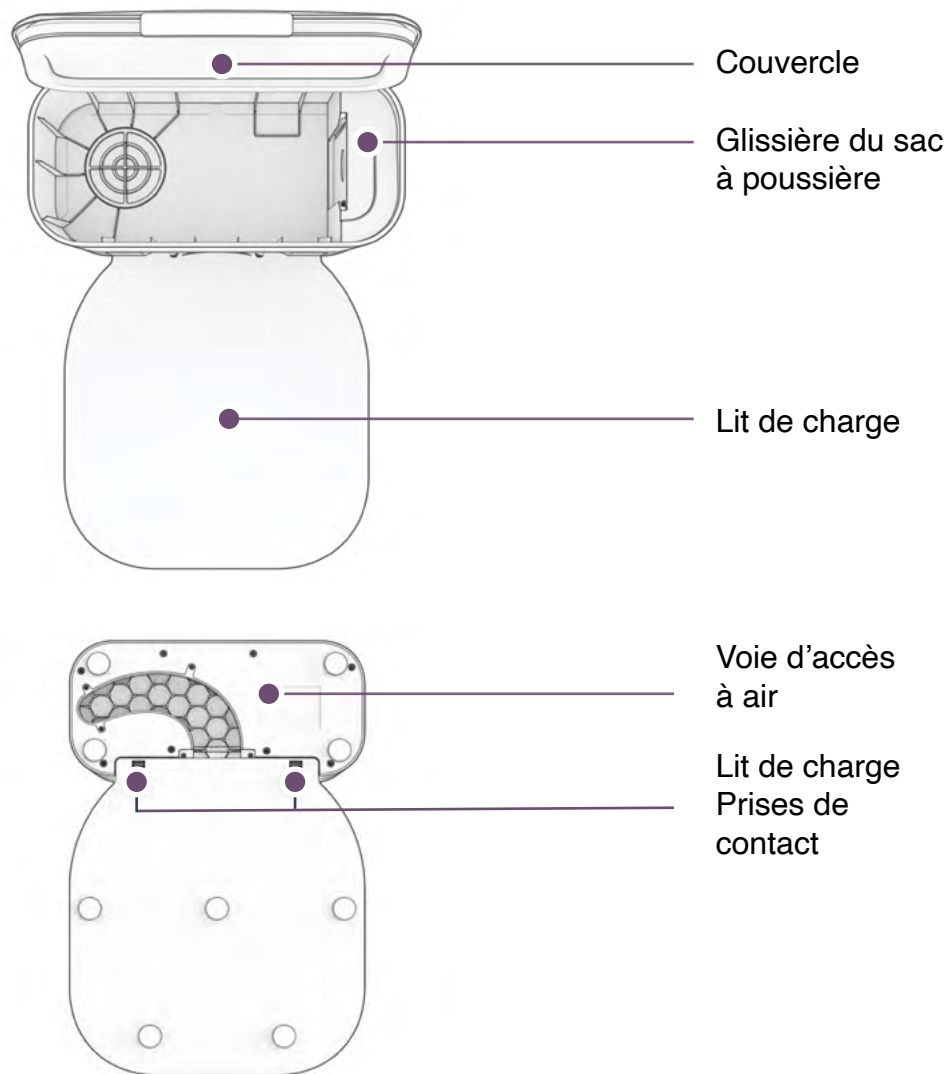

Poubelle et Accessoire à nettoyage

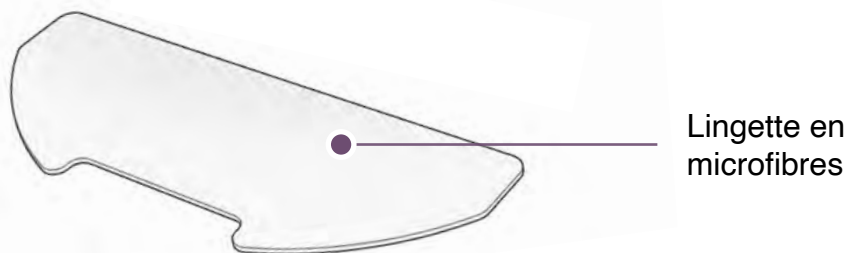
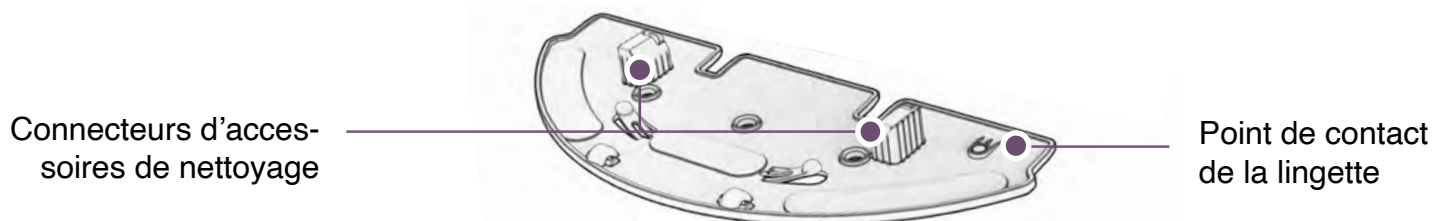
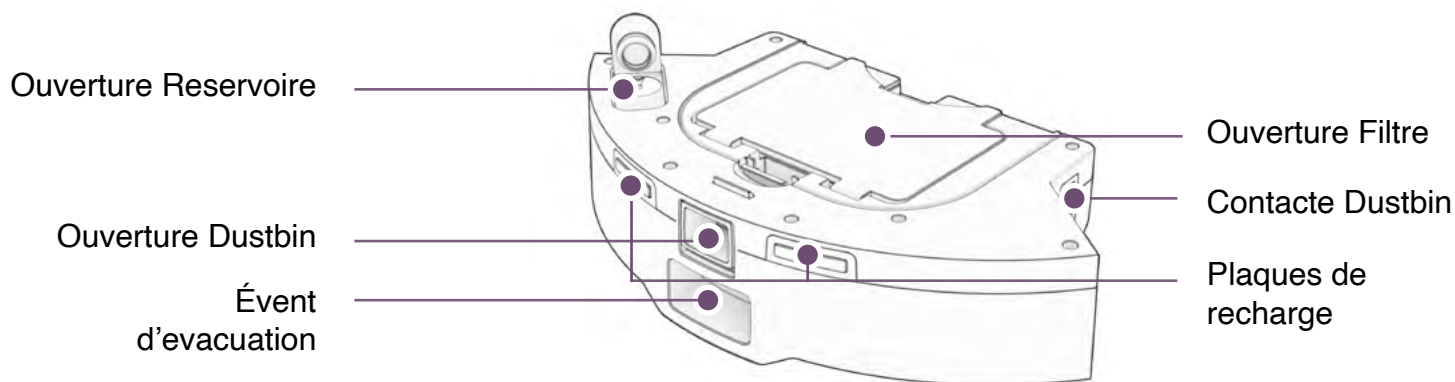

Qui est UltraVision?

UltraVision est un robot aspirateur autonome, à votre service ! Connectez UltraVision au Wi-Fi et utilisez l'application bObsweep pour créer un plan de nettoyage personnalisé. UltraVision nettoiera votre maison, à votre manière.

Comment UltraVision s'y prend-il pour s'orienter ?

UltraVision utilise la vision laser, un réseau de capteurs et une technologie de cartographie et de localisation de pointe pour détecter les murs, les meubles et les obstacles.

Tout en nettoyant, UltraVision crée une carte des zones auxquelles il peut accéder et qu'il peut nettoyer. Les zones où se trouvent les meubles et les petits objets sont marquées sur la carte. Vous pouvez afficher la carte en cliquant sur l'icône Carte de l'application bObsweep et la personnaliser à votre guise. En utilisant la carte et les critères de personnalisation de l'application, UltraVision nettoie efficacement votre maison au cours d'un cycle complet.

Après le nettoyage, UltraVision retourne à sa station et vide sa poubelle dans le conteneur de sa station de recharge. Oubliez le nettoyage et profitez de sols propres pendant des semaines !

Découvrez les fonctions de la carte de UltraVision :



Plus de vidéos et d'instructions :



Franchir des obstacles difficiles

Meuble unique

Les meubles spéciaux, tels que les chaises de bureau à roulettes ou les tabourets à base circulaire, peuvent perturber UltraVision momentanément ; il peut rester coincé sur un rebord pendant quelques minutes, puis décider de nettoyer ailleurs.

Tant que UltraVision n'affiche pas de message d'erreur, laissez-le continuer à nettoyer et à trouver son propre chemin. Prenez note des zones que UltraVision trouve les plus difficiles et, si possible, ajustez les meubles ou ajoutez des zones NoSweep™.

Tapis sombres

Si UltraVision recule de manière répétée ou affiche un message d'erreur lors du nettoyage de tapis sombres, désactivez les capteurs de bord.

Pour les désactiver, ouvrez l'application bObsweep et désactivez " Edge detection" dans Settings .

N'oubliez pas que si les capteurs de bord de UltraVision sont désactivés, il ne pourra pas détecter les bords ou les escaliers et tombera du bord s'il s'en approche ! Ajoutez une ligne NoSweep à l'endroit du bord ou de l'escalier pour assurer la sécurité de UltraVision.

Tapis a poil long

La brosse principale de UltraVision n'est pas conçue pour nettoyer les tapis à poils longs ou les tapis à fibres longues et à franges. Si vous souhaitez que UltraVision nettoie des tapis à poils longs ou à fibres longues, vous pouvez lui retirer sa brosse principale et lui permettre de passer l'aspirateur sans elle.

Mopping

Ajoutez des zones NoMop aux endroits où se trouvent des tapis ou des moquettes pour empêcher UltraVision d'y pénétrer lors du nettoyage humide.

Premier Nettoyage de UltraVision

Installez la Brosse Latérale de UltraVision

Installez la brosse latérale de UltraVision pour l'aider à atteindre les coins et les bords des pièces.

Pièces nécessaires :

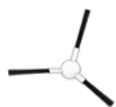

Brosse Latérale

Avant de commencer

Retirer les pièces de protection de UltraVision, de son bumper et de la station de charge.



Placez la brosse latérale sur le socle vide de UltraVision. Appuyez pour fixer.

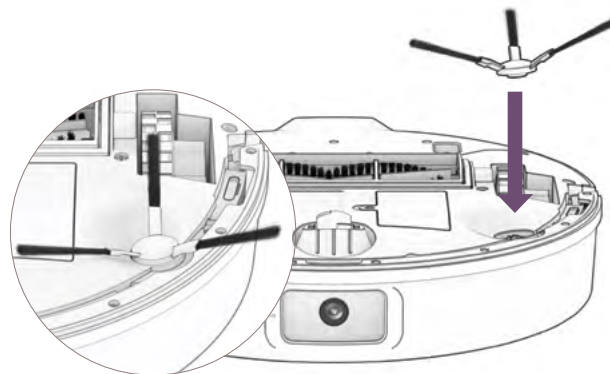

Note Importante : La force de la fixation de la brosse latérale peut être augmentée en tournant la vis au centre de la brosse latérale dans le sens inverse des aiguilles d'une montre.

Premier Nettoyage de UltraVision

Allumer UltraVision

Appuyez sur le bouton GO et maintenez-le enfoncé jusqu'à ce que l'écran s'allume.

Conserver

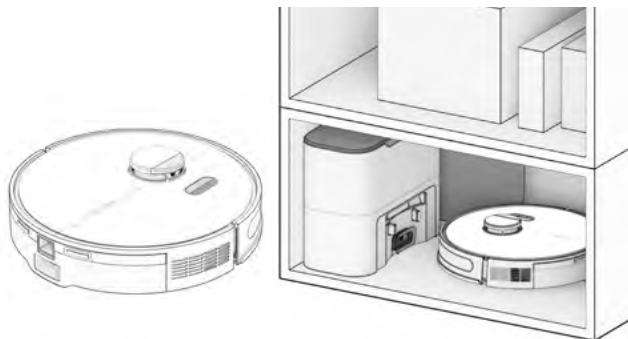

Si vous n'utilisez pas UltraVision pendant une période prolongée (plus d'un mois), éteignez-le, retirez sa batterie et débranchez sa station de charge. Stockez le tout dans une pièce sèche, à l'abri de la lumière directe du soleil et des températures extrêmes.

Si vous n'avez pas l'intention d'utiliser UltraVision pendant un certain temps, vous pouvez le mettre en mode veille à faible consommation (mode LPS). Dans ce cas, placez UltraVision sur sa station de charge. Appuyez sur le bouton CHARGE de UltraVision et maintenez-le enfoncé pendant 5 secondes. Vous entendrez "low power mode", confirmant que UltraVision est en mode LPS. Pour quitter ce mode, appuyez sur le bouton GO de UltraVision lorsqu'il est sur la station de charge, ou retirez-le de la station.



Note Important : Dans ce mode, UltraVision est hors ligne et l'application bObsweep ne peut pas se connecter à UltraVision. De plus, tout nettoyage programmé sera mis en pause.

Premier Nettoyage de UltraVision

Mise en place de la station de UltraVision

La lumière vive du soleil, les surfaces brillantes et les objets réfléchissants peuvent interférer avec les signaux d'amarrage de UltraVision. Placez la station de UltraVision loin des fenêtres non couvertes, des miroirs et des meubles ou objets brillants.

Pièces nécessaires :



Station de recharge



Lit de recharge

Positionnement

UltraVision retourne à sa station de recharge après avoir nettoyé. Pour aider UltraVision, placez la station de recharge sur une surface plane et dure, loin des bords et des escaliers, avec suffisamment d'espace autour.

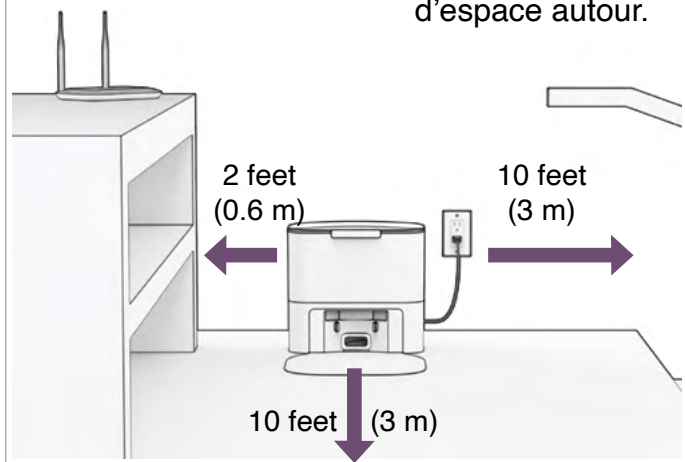

Placez la station de recharge sur les socles du lit de recharge. Appuyez pour la maintenir en place.

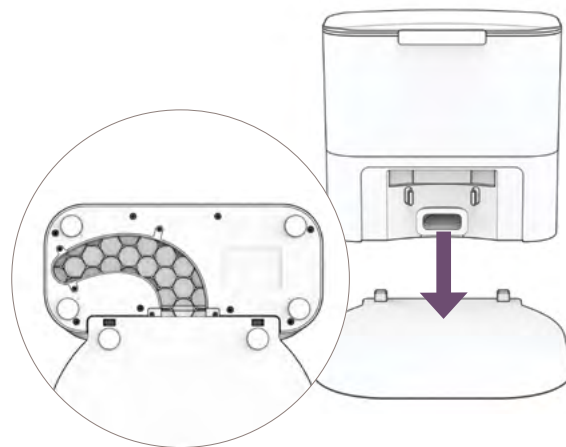

Quick Tip: Les socles du lit de recharge s'insèrent dans la station de recharge située à l'avant de celui-ci.

Premier Nettoyage de UltraVision

Indicateurs de la station de recharge

Lorsque UltraVision a fini de stationner sur sa station de recharge et qu'il n'y a pas d'erreur de la station, le voyant lumineux de la station s'éteint.

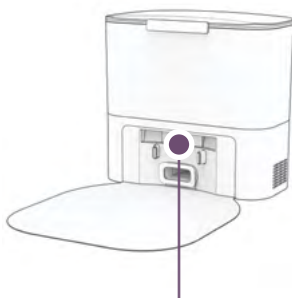

État de LED	État de la station	Ce qu'il faut faire
● Désactivé	Eteint	Brancher dans la prise de courant.
● Bleu	Prés	Envoyer UltraVision pour charger/s'auto-vider.
● Rouge uni	Le sac à poussière n'est pas détecté/l'ouverture du sac à poussière est fermée	Insérer le sac à poussière dans la glissière et pousser la languette vers le bas pour l'ouvrir et l'aligner avec le passage d'air.
● Rouge clignotant	Encombrement de la voie aérienne	<ul style="list-style-type: none">-Retirez et ouvrez le poubelle afin de le nettoyer et de le débarrasser des encombrements importants.-Nettoyez l'orifice d'évacuation situé à l'arrière du dustbin. Vérifiez que le clapet se déplace librement.-Débranchez la station puis ouvrez la fenêtre d'accès au passage d'air pour éliminer les encombrements du passage d'air.- Placez UltraVision sur la station et appuyez « Charge » pour lancer un auto-vider. Si cela ne résout pas le problème: <ul style="list-style-type: none">- Débranchez la station, retournez la station pour ouvrir la voie d'accès à air. Accédez à la fenêtre et supprimez tout congestion.- Placez UltraVision sur la station et appuyez « Charge » pour lancer une auto-vider.

Premier Nettoyage de UltraVision

Rechargé UltraVision

Appuyez sur le bouton CHARGE de UltraVision pour l'envoyer à sa station de recharge.

Pièces nécessaires :



Station de recharge & d'autovidage

Charging Indicator



Batterie Fiable :  Cligne rapidement.

Recherche Station :  Cligne.

En charge :  Cligne lentement.

Chargé :  Brille en blanc.

Pour recharger UltraVision manuellement, placez-le sur son lit de recharge, les nœuds métalliques de son dos reposant sur les plaques de la station.

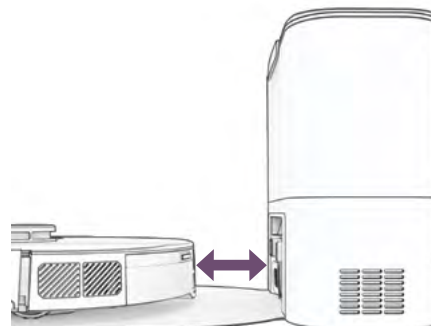

Quick Tip: UltraVision vide son bac à chaque fois qu'il se stationne à la fin d'une session de nettoyage. Définissez la fréquence à laquelle UltraVision se vide lui-même dans "Cleaning Preferences" sur l'application bObsweep.

Premier Nettoyage de UltraVision

Télécharger l'application bObsweep

Connectez UltraVision au Wi-Fi pour accéder à l'ensemble des fonctionnalités de UltraVision et aux mises à jour logicielles importantes. Suivez les instructions de l'application pour vous connecter aux appareils Amazon Alexa ou Google Home.

Articles nécessaires :



Smart Phone



Connexion Wi-Fi 2.4GHz

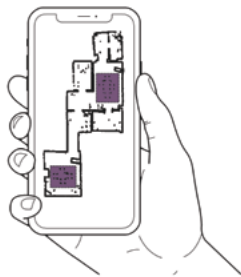

UltraVision cartographie la zone au premier coup d'œil. Modifiez, personnalisez la carte de nettoyage de UltraVision, puis définissez des horaires de nettoyage et profitez de sols propres sans avoir à lever le petit doigt pendant plusieurs semaines d'affilée.

Ouvrez l'application bObsweep, créez votre compte et suivez les instructions pour connecter votre robot.



Premier Nettoyage de UltraVision

Laissez UltraVision balayer !

UltraVision est maintenant prêt à balayer ! Éliminez tout encombrement ou câble et appuyez sur le bouton GO.

Levage et déménagement

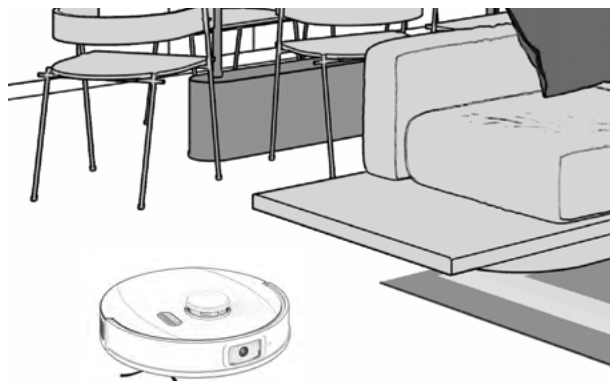

Ne soulevez pas UltraVision pendant le nettoyage pour éviter de déformer sa carte.

Ne changez pas l'emplacement de la station de UltraVision une fois la carte terminée.

Doté de la technologie de nettoyage Room-to-Room™, UltraVision explore et nettoie automatiquement votre maison, en évitant les meubles et les obstacles sur son chemin. Pour de meilleurs résultats, retirez le désordre et les petits objets.



Pour une meilleure performance

Pour optimiser l'efficacité de UltraVision, il est préférable de maintenir ses brosses, ses filtres et ses capteurs propres.

Partie	Maintenance recommandé	Remplacement Frequency
Poubelle et Station	Au mois	
Filtre	Au mois	Tous les 6 mois
Brosses	Chaque semaine	Tous les 12 mois
Capteurs	Chaque semaine	
Roue avant	Chaque semaine	
Batterie		Tous les 24 à 36 mois

Quick Tips: Enlevez les débris des coins et recoins autour des brosses et des roues.

Utilisez une pince à épiler pour éliminer la congestion des extrémités des brosses et des compartiments de la brosse principale et des brosses latérales de UltraVision.

Utilisez des ciseaux ou l'outil de nettoyage fourni pour couper les poils qui s'enroulent autour des brosses.



Sac de poussière

1. Ouvrez le couvercle.



2. Tirez la languette vers le haut pour fermer l'ouverture du sac à poussière. Soulever pour retirer le sac à poussière plein et le jeter.

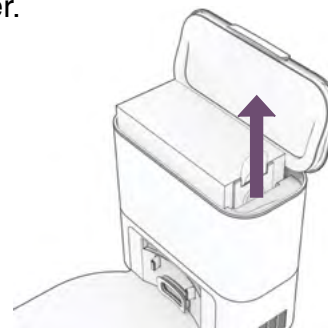

3. Placez le nouveau sac à poussière, en faisant glisser la carte complètement en place. Faites glisser la languette d'ouverture vers le bas.

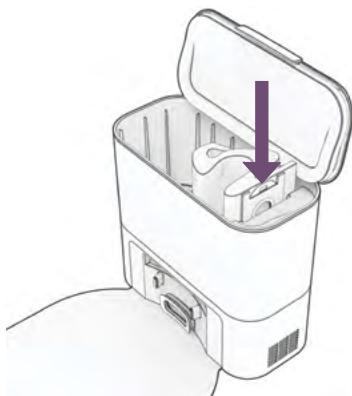

4. Fermez le couvercle.

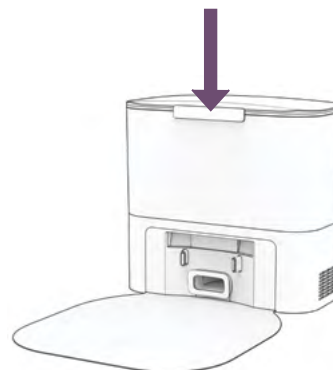

Station de recharge et d'autovidage

Avant de nettoyer la station de recharge, débranchez-la.

1. Essuyez les nœuds de charge (points de contact).



2. Essuyer la fenêtre de l'émetteur, en s'assurant qu'elle n'est pas bloquée ou couverte.



3. Retirez le sac à poussière et nettoyez le bac à poussière pour éviter l'accumulation de débris ou toute obstruction à la libre circulation de l'air.



4. Débranchez la station. Inspectez l'évent d'évacuation et le passage de l'air. Nettoyez et éliminez tout encombrement.

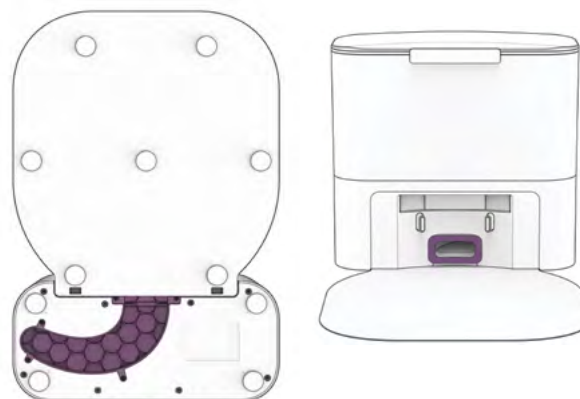

Brosses

1. Tirez vers le haut pour retirer la brosse latérale.

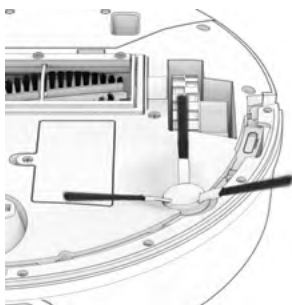

2. Retirez les débris de la brosse latérale et son logement.



3. Pincez les languettes de la porte principale des brosses et soulevez-la.

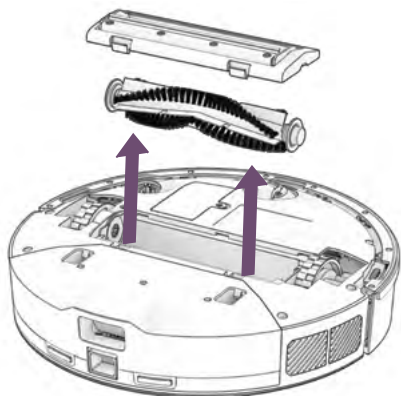

4. Nettoyez le balai principal et tous ses composants, y compris la porte de la brosse et le compartiment de la brosse.

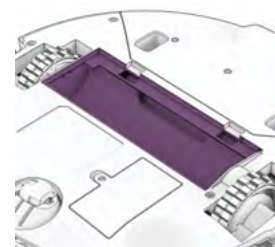

Maintenance

Capteurs

Utilisez un chiffon doux en coton pour essuyer les capteurs.

1. Essuyez les capteurs de bord et de mur.

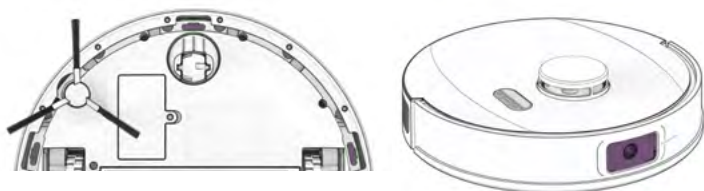

2. Essuyez les nœuds de charge sur UltraVision et sa station.



3. Essuyez les connecteurs métalliques du de la poubelle et de la serpillière.

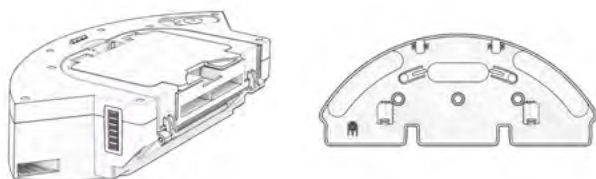

4. Essuyez la partie supérieure et la zone autour du SLAM LiDAR.

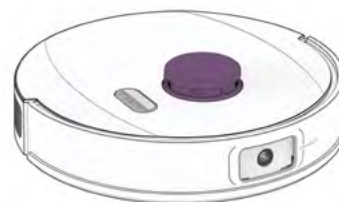

Remarque importante :

Le SLAM LiDAR de UltraVision est un capteur sensible. N'appliquez pas de force, n'insérez pas d'objets et ne réglez pas le SLAM LiDAR. Ne vous asseyez pas sur UltraVision et ne placez pas d'objets sur lui.

Roue avant

1. En utilisant un tournevis à tête plate comme levier, saisissez fermement la roue et tirez, saisissez fermement la roue et tirez.



2. Une fois la roue retirée, utilisez le tournevis pour extraire l'ensemble de la roue.

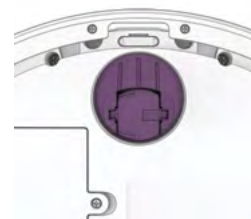

3. Nettoyez la roue et tous ses composants, y compris l'assemblage et la douille de la roue.

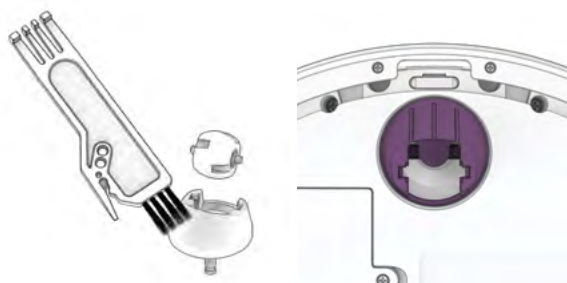

4. Remettez les deux parties en place lorsque c'est fait. Poussez vers le bas pour les verrouiller en place.

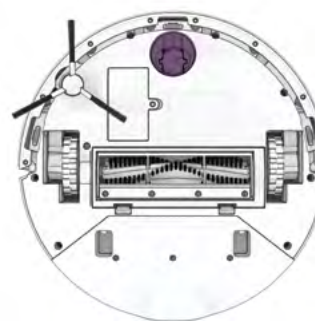

Batterie

Eteignez UltraVision avant de remplacer la pile. Appuyez sur le bouton GO et maintenez-le enfoncé.

1. Utilisez un tournevis cruciforme pour ouvrir le compartiment à piles.

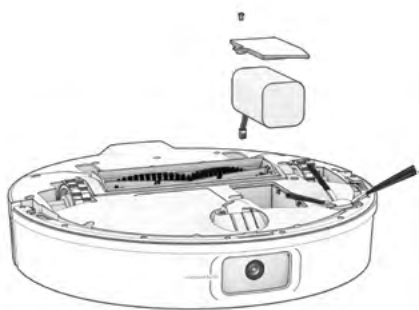

2. Débranchez l'ancienne batterie et branchez la nouvelle.



3. Glissez la nouvelle batterie dans UltraVision.

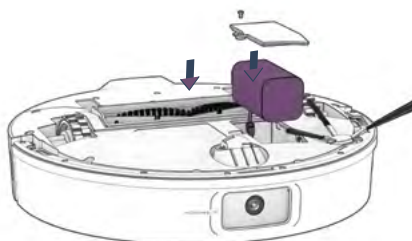

Note importante : Le mode haute puissance augmente de façon exponentielle l'utilisation de la batterie de UltraVision. Utilisez le mode basse consommation pour réduire la consommation d'énergie de UltraVision.

Accessoire de Nettoyage

1. Retirer la poubelle.

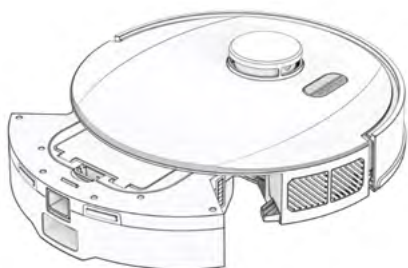

2. Ouvrez la languette du réservoir et remplissez-le avec de l'eau. Utilisez de l'eau distillée dans les régions où l'eau est calcaire.

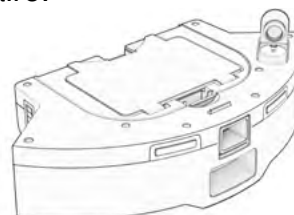

3. Alinez les connecteurs de l'accessoire de nettoyage avec ceux de la poubelle et appuyez pour verrouiller en place.

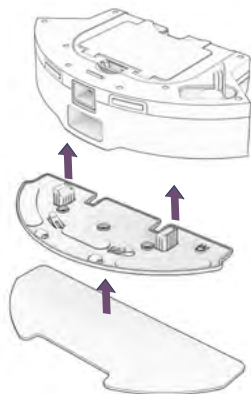

4. Remplacez la poubelle.

Remarque : si l'accessoire de nettoyage est connecté, UltraVision n'entrera pas dans les zones NoMop.

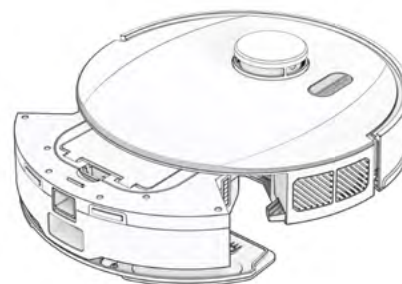

Maintenance de l'accessoire de Nettoyage :

Le réservoir doit être vidé après utilisation afin d'éviter tout dommage causé par l'eau.

1. Retirer l'accessoire de nettoyage.

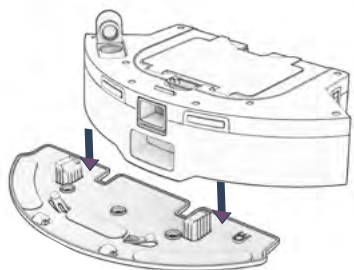

2. Ouvrez la languette et videz le réservoir.

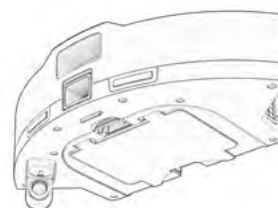

3. Laver la serpillière. Sécher à l'air toutes les parties une fois fini.

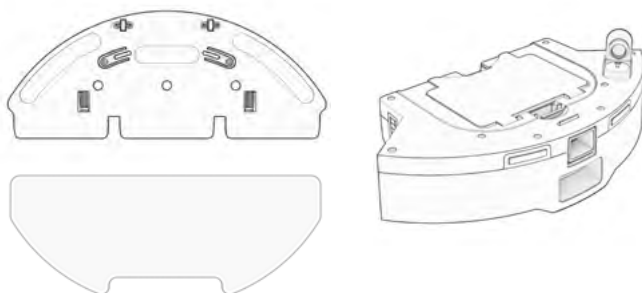

4. Découvrez les fonction de l'accessoire de Nettoyage de UltraVision :



Dépannage

Lorsque UltraVision rencontre un problème, il s'arrête et son indicateur de trouble clignote. Consultez l'application bObsweep pour connaître les détails des problèmes.

Trouble	Solution
Battery	Batterie faible ou déconnectée. Vérifier la connexion. Réinitialisez et chargez UltraVision.
Left/Right Wheel	La roue gauche/droite est bloquée. Vérifier qu'il n'y a pas d'obstruction et nettoyer.
Main/Side Brush	La brosse principale / latérale est obstruée. Retirer et nettoyer.
Camera	Erreur de composant de la caméra. Réinitialisez UltraVision (Éteignez et allumez UltraVision).
Dustbin	Poubelle est déconnectée ou les points de contact sont sales. Nettoyez les points de contact et remettez-les en place. Ou le moteur d'aspiration est bloqué. Vérifier qu'il n'y a pas d'obstruction et nettoyer.
Mop Attachment	UltraVision essaie de nettoyer mais l'accessoire est déconnecté ou les points de contact sont sales. Vérifier qu'il n'y a pas d'obstruction et nettoyer.
Edge Sensors	UltraVision est coincé près d'un bord, ou n'est pas en contact avec le sol ou les capteurs de bord sont sales. Mettez UltraVision en sécurité et nettoyez les capteurs de bord.
Bumper	Le Bumper est sale ou bloqué. Essuyez autour du bumper ; éliminez toute obstruction.
LiDAR Bumper	Le bumper du SLAM LiDAR est bloqué. Vérifiez qu'il n'y a pas d'obstruction et nettoyez-le.
LiDAR	Le SLAM LiDAR n'est pas propre/perte de visibilité. Nettoyez le SLAM LiDAR et éloignez UltraVision des miroirs/des surfaces métalliques/des murs et placez-le au centre de la pièce.
Charging Station	Impossible de localiser la station de recharge. Rebranchez la station de charge et chargez.
User Interface	L'interface utilisateur de UltraVision/le port USB ne répond pas. Réinitialisez UltraVision et assurez-vous que le port USB est vide.
Electronic	Erreur de composant électronique. Réinitialisez UltraVision (Éteignez et allumez UltraVision).
Stuck	UltraVision est coincé. Éliminez les obstacles, et les fils et réinitialisez UltraVision.
Navigation	UltraVision ne peut pas naviguer. Éliminez les encombrements et les fils et réinitialisez UltraVision.
Localization	UltraVision ne peut pas se repérer sur la carte. Vérifier l'exactitude de la carte/effacer la carte pour la refaire.
Settings	Les paramètres actuels de la chambre ne correspondent pas à ceux de UltraVision. Modifier les paramètres/horaires de la carte.

Test de contrôle check-up

Si UltraVision ne fonctionne pas aussi bien qu'il le devrait, vous pouvez diagnostiquer le problème à l'aide d'un simple test de contrôle check-up.

Mettre UltraVision en mode check-up :

Appuyez simultanément sur les boutons "GO", "CHARGE" et "WI-FI" et maintenez-les enfoncés pendant quelques secondes jusqu'à ce que le robot indique : "Home Checkup Mode Activated" (Mode de contrôle à domicile activé). Dans ce mode, le capteur LiDAR de UltraVision tourne.

Pour quitter le mode check-up :

Appuyez à nouveau simultanément sur les boutons "GO", "CHARGE" et "WI-FI". Vous entendrez "Exiting Home Checkup Mode" et le capteur LiDAR de UltraVision s'arrêtera de tourner.

Notes Importantes :

- Pendant le test, si UltraVision reste inactif pendant plus d'une minute, il quittera automatiquement le test de contrôle à domicile.
- Pour passer d'une étape à l'autre du test de contrôle, appuyez sur le bouton Wi-Fi.
- Pour démarrer/arrêter les tests à chaque étape, appuyez sur le bouton GO jusqu'à ce que vous entendiez "Begin test" et "Stop test". Arrêtez toujours un test avant de passer à l'étape suivante.

Etape	Partie (s) Testé	Description
1	Battery	Après une charge complète, testez la batterie de UltraVision.
2	Edge Sensors	Testez les capteurs de bord.
3	Charging Station	Tester les capteurs de charge.
4	Bumpers, Wi-Fi, and Camera	Testez le module Wi-Fi, capteurs tactiles et caméra
5	Motors (wheels, brushes, vacuum, mop)	Test chacun des moteurs de UltraVision individuellement.
6	SLAM LiDAR, Charging and Self-empty	Testez le SLAM LiDAR de UltraVision, les points de contact de charge et la fonction d'auto-vidage.
7	Hard Resetting UltraVision	Réinitialisez UltraVision aux paramètres d'usine et effacez toutes les données.

Guide vidéo étape par étape du test de contrôle check-up: bobsweep.com/ultravision-support.

FAQs

UltraVision ne s'allume pas, quoi que je fasse.

Si UltraVision ne réagit pas aux boutons, sa batterie est probablement trop faible pour qu'il puisse fonctionner. Placez UltraVision sur sa station de chargement et laissez-le se recharger complètement. Lorsque vous le placez sur la station, assurez-vous que la poubelle est bien enclenchée et que les nœuds de charge situés à l'arrière de UltraVision sont parfaitement alignés avec ceux de sa station de charge.

UltraVision doit être rechargé avant de terminer la cartographie de ma maison.

Utilisez la fonction Swift Map de l'application bObsweep pour demander à UltraVision de cartographier les sols sans les nettoyer. Dans ce mode, UltraVision explore et cartographie la maison, puis retourne à sa borne de recharge sans la nettoyer. Assurez-vous qu'UltraVision est complètement chargé avant de lancer cette fonctionnalité.

UltraVision ne ramasse plus autant qu'avant.

UltraVision aura du mal à se nettoyer si son bac à poussière est bouché ou si sa brosse principale est obstruée ou emmêlée de poils. Retirez la brosse principale de UltraVision et nettoyez-la soigneusement d'un bout à l'autre. Retirez et ouvrez le bac à poussière, et enlevez tous les gros débris du bac à poussière de UltraVision pour assurer une bonne circulation de l'air.

Comment puis-je savoir que UltraVision est complètement chargé et prêt à nettoyer ?

Lorsque UltraVision est en cours de chargement, le voyant de chargement clignote lentement. Lorsque UltraVision est entièrement chargé et prêt à nettoyer, l'indicateur de charge brille en blanc.

UltraVision a du mal à trouver son poste.

Assurez-vous que le lit de recharge de UltraVision est installé. Vous devrez peut-être déplacer la station de UltraVision dans un endroit plus accessible. Assurez-vous que la station est placée dans une zone centrale, sur une surface dure et plate, loin des escaliers ou des bords, de la lumière directe du soleil, des miroirs ou des surfaces réfléchissantes, et avec beaucoup d'espace libre autour d'elle. Ensuite, effacez l'ancienne carte et laissez UltraVision refaire la carte de la maison à partir de sa nouvelle station.

Est ce que je peux passer prendre UltraVision ?

Il n'est pas recommandé de prendre et de déplacer UltraVision pendant une session de nettoyage, car cela peut affecter son cycle de nettoyage/carte en cours. En outre, il est préférable de ne pas déplacer la station de charge de UltraVision une fois qu'il a cartographié son environnement. Si vous devez déplacer la station, effacez l'ancienne carte et laissez UltraVision cartographier à nouveau la maison.

Impossible de connecter UltraVision au Wi-Fi.

Vous pouvez connecter UltraVision à un Wi-Fi 2,4 GHz une fois qu'il est complètement chargé. Activez «Location Services» et «Bluetooth» dans votre téléphone. Autorisez également l'accès au «Local Networks» et désactivez les «Wi-Fi Calling» sur votre téléphone. Notez votre réseau Wi-Fi 2,4 GHz et son mot de passe (notez qu'ils sont sensibles à la casse). Rapprochez UltraVision et votre téléphone de votre modem ou routeur et assurez-vous de sélectionner le nom de modèle correct «UltraVision» dans la liste des robots.

UltraVision peut-il nettoyer ma maison à plusieurs étages ?

Oui. UltraVision peut sauvegarder jusqu'à 3 cartes d'étage. Pour obtenir des instructions étape par étape sur la façon de sauvegarder les cartes, visitez : bobsweep.com/UltraVision-support.

UltraVision a arrêté le nettoyage et l'indicateur de panne clignote.

Lorsque UltraVision est en difficulté et a besoin de votre aide, il s'arrête et l'indicateur de panne clignote. Ouvrez l'application bObsweep et trouvez les détails du problème en haut de la page Control.

UltraVision est Offline.

UltraVision est peut-être en veille prolongée ou est éteint et s'est déconnecté du Wi-Fi. Pour le remettre en ligne, placez-le sur la station de recharge et laissez-le se charger et s'allumer. Pour obtenir des instructions visitez : bobsweep.com/UltraVision-support.

UltraVision est souvent coincé.

S'il y a des zones à problèmes répétés dans la maison sous lesquelles UltraVision se coince ou s'arrête, dessinez des zones NoSweep au-dessus de ces zones sur la carte pour éviter à UltraVision d'avoir des ennuis.

Comment puis-je diagnostiquer le problème exact de UltraVision ?

Si UltraVision n'est pas aussi performant qu'il le devrait, vous pouvez diagnostiquer le problème à l'aide d'un test de contrôle à domicile. Pour plus d'informations sur la manière d'effectuer ce test, consultez : bobsweep.com/UltraVision-support.

Puis-je modifier ou supprimer la carte que UltraVision a créée ?

Oui. La carte de UltraVision est entièrement personnalisable et modifiable. Examinez la carte créée par UltraVision et apportez-y toutes les modifications que vous souhaitez. Pour des instructions étape par étape, visitez : bobsweep.com/UltraVision-support.

End User License Agreement

IMPORTANT - READ BEFORE USING. Do not use the robot (“UltraVision” or “bObsweep”) accompanying this license agreement (“Agreement”) until you have carefully read and agreed to the following terms and conditions.

By using the bObsweep, you agree to the terms of this End User License Agreement (“EULA”) and any amendment or addenda accompanying this Agreement. If you do not agree to the terms of this EULA, you may not use the bObsweep. The bObsweep contains an electronic and software interface that allows you to control or modify its behavior, and remotely monitor its sensors.

THIS IS A LEGAL AGREEMENT. BY ACCESSING AND USING THE PRODUCT AND PRODUCT SOFTWARE, YOU ARE ACCEPTING AND AGREEING TO THIS EULA ON BEHALF OF YOURSELF OR THE ENTITY YOU REPRESENT IN CONNECTION WITH THE ACCESS. YOU REPRESENT AND WARRANT THAT YOU HAVE THE RIGHT, AUTHORITY, AND CAPACITY TO ACCEPT AND AGREE TO THIS EULA ON BEHALF OF YOURSELF OR THE ENTITY YOU REPRESENT. YOU REPRESENT THAT YOU ARE OF SUFFICIENT LEGAL AGE IN YOUR JURISDICTION OR RESIDENCE TO USE OR ACCESS THE PRODUCT SOFTWARE AND TO ENTER INTO THIS EULA. IF YOU DO NOT AGREE WITH ANY OF THE PROVISIONS OF THESE TERMS, YOU SHOULD CEASE USING THE PRODUCT AND PRODUCT SOFTWARE.

Terms and Conditions

LICENSE: Subject to all of the terms of this Agreement, Bobsweep Inc. (“bObsweep”) grants to you one (1) revocable, royalty-free, personal, non-exclusive, non-transferable, non-assignable, non-commercial intellectual property license to use the Bobsweep software contained on the bObsweep (“Bobsweep Software”), including the protocol for communicating with the bObsweep Software, and to use the bObsweep.

NONCOMMERCIAL LICENSE: You may use the Bobsweep Software and the bObsweep only for personal, non-commercial, educational, and research purposes. The Bobsweep Software and the bObsweep may not be used for any other purpose, whether “for profit” or “not for profit.” Any work performed or produced using the bObsweep, including any software that you create for your bObsweep (“Your Software”), cannot be performed or produced for the benefit of other parties for a fee, compensation, or any other reimbursement or remuneration. A separate license is required for each additional use and/or individual user in all other cases. If you are an entity, Bobsweep grants you the right to designate one individual within your organization to have the sole right to use the Bobsweep Software and the bObsweep in the manner provided above.

RESTRICTIONS: You agree not to: (i) use or copy the Bobsweep Software or the bObsweep except as provided in this Agreement; (ii) rent or lease the Bobsweep Software or the bObsweep to any third party; (iii) assign this Agreement or transfer the Bobsweep Software or the bObsweep except as provided in this Agreement; (iv) modify, adapt, or translate the Bobsweep Software or the bObsweep in whole or in part except as expressly provided in this Agreement; (v) reverse engineer, reverse compile, or disassemble the Bobsweep Software or the bObsweep; or (vi) distribute, sublicense or transfer the source code form of Your Software and derivatives thereof to any third party except as provided in this Agreement.

YOUR SOFTWARE : Your Software is also subject to the following limitations: You (i) shall be solely responsible for any update or support obligation or other liability which may arise from your use or distribution, (ii) shall not make any statement that Your Software is “certified,” or that its performance is guaranteed, by Bobsweep, (iii) shall not use Bobsweep’s

or trademarks, (iv) shall prohibit disassembly and reverse engineering of the bObsweep Software and the bObsweep, (v) shall not publish reviews of bObsweep products designated as beta without written permission from bObsweep, and (vi) shall indemnify, hold harmless, and defend bObsweep and its suppliers from and against any claims or lawsuits, including attorney's fees, that arise or result from Your Software, including your use and your distribution.

TITLE: Title to the bObsweep Software remains with bObsweep or its suppliers. The bObsweep Software is licensed, not sold. Except as expressly provided herein, bObsweep does not grant any express or implied right to you under bObsweep patents, copyrights, trademarks, or trade secret information. You will not remove any copyright or patent notice from the bObsweep Software or the bObsweep.

ONE-TIME TRANSFER: The initial user of the bObsweep Software and the bObsweep may make a one-time permanent transfer of this Agreement, the bObsweep Software, and the bObsweep to another end user, provided that the initial user retains no copies of the bObsweep Software and the bObsweep. This transfer must include the bObsweep Software, the bObsweep, and all of the materials accompanying the bObsweep (including all component parts and printed materials, any upgrades, and this End User License Agreement document). The transfer may not be an indirect transfer, such as a consignment. Prior to the transfer, the end user receiving the bObsweep Software and the bObsweep must agree to all the terms of this Agreement.

NO WARRANTY AND LIMITED REPLACEMENT: EXCEPT AS STATED IN THE LIMITED WARRANTY TO THE ORIGINAL PURCHASER, THE SOFTWARE AND THE BOBSWEEP ARE PROVIDED "AS IS" WITH NO WARRANTIES, EXPRESS OR IMPLIED, INCLUDING BUT NOT LIMITED TO ANY IMPLIED WARRANTY OF MERCHANTABILITY, FITNESS FOR A PARTICULAR PURPOSE, NON-INFRINGEMENT OF INTELLECTUAL PROPERTY RIGHTS, OR ANY WARRANTY OTHERWISE ARISING OUT OF ANY PROPOSAL, SPECIFICATION, OR SAMPLE. NO ORAL OR WRITTEN INFORMATION OR ADVICE GIVEN BY BOBSWEEP OR ITS AGENTS SHALL CREATE A WARRANTY.

If the Bobsweep Software or the bObsweep is found to be defective in material or workmanship under normal use for a period of one (1) year from the date of receipt, Bobsweep's entire liability and your exclusive remedy shall be the replacement of the Bobsweep Software or the bObsweep. This offer is void if the defect results from accident, abuse, misapplication, or software that you developed for your bObsweep. Any updates or supplements to the Bobsweep Software or the bObsweep provided to you after the expiration of the one (1) year period are not covered by any warranty or condition, express, implied or statutory.

SOME JURISDICTIONS DO NOT ALLOW THE EXCLUSION OF IMPLIED WARRANTIES, SO THE ABOVE EXCLUSION MAY NOT APPLY TO YOU. LIMITATION OF LIABILITY: THE ABOVE REPLACEMENT PROVISION IS THE ONLY WARRANTY OF ANY KIND. BOBSWEEP OFFERS NO OTHER WARRANTY EITHER EXPRESS OR IMPLIED INCLUDING THOSE OF MERCHANTABILITY, NON INFRINGEMENT OF THIRD- PARTY INTELLECTUAL PROPERTY OR FITNESS FOR A PARTICULAR PURPOSE. NEITHER BOBSWEEP NOR ITS SUPPLIERS SHALL BE LIABLE FOR ANY DAMAGES WHATSOEVER (INCLUDING, WITHOUT LIMITATION, VICARIOUS LIABILITY, CONSEQUENTIAL DAMAGES, INCIDENTAL DAMAGES, DAMAGES FOR LOSS OF BUSINESS PROFITS, BUSINESS INTERRUPTION, LOSS OF BUSINESS INFORMATION, OR OTHER LOSS) ARISING OUT OF THE USE OF OR INABILITY TO USE THE BOBSWEEP SOFTWARE, THE BOBSWEEP, OR SOFTWARE THAT YOU DEVELOPED FOR YOUR BOBSWEEP, EVEN IF BOBSWEEP HAS BEEN ADVISED OF THE POSSIBILITY OF SUCH DAMAGES. BECAUSE SOME JURISDICTIONS

PROHIBIT THE EXCLUSION OR LIMITATION OF LIABILITY FOR CONSEQUENTIAL OR INCIDENTAL DAMAGES, THE ABOVE LIMITATION MAY NOT APPLY TO YOU UNAUTHORIZED USE: THE BOBSWEEP SOFTWARE AND THE BOBSWEEP ARE NOT DESIGNED, INTENDED, OR AUTHORIZED FOR USE IN ANY AERONAUTICAL, NUCLEAR, MEDICAL, LIFE SAVING OR LIFE SUSTAINING SYSTEMS, OR FOR ANY OTHER APPLICATION IN WHICH THE USE OF THE BOBSWEEP SOFTWARE OR THE BOBSWEEP COULD CREATE A SITUATION WHERE PERSONAL INJURY OR DEATH MAY OCCUR.

Should you use the Bobsweep Software or bObsweep for any such unintended or unauthorized use, you shall indemnify and hold harmless Bobsweep and its officers, subsidiaries and affiliates against all claims, costs, damages, and expenses, and reasonable attorney fees arising out of, directly or indirectly, any claim of product liability, personal injury or death associated with such unintended or unauthorized use, even if such claim alleges that Bobsweep was negligent regarding the design or manufacture of the Bobsweep Software, the bObsweep, or any part or portion thereof.

USER SUBMISSIONS: You agree that any material, information or other communication, including all data, images, sounds, text, and other things embodied therein, that you transmit or post to a Bobsweep website or provide to Bobsweep (“Communications”) will be considered non-confidential. Bobsweep will have no confidentiality obligations with respect to the Communications. You agree that Bobsweep and its designees will be free to copy, modify, create derivative works, publicly display, disclose, distribute, license and sublicense through multiple tiers of distribution and licensees, incorporate and otherwise use the Communications, including derivative works thereof, for any and all commercial or non-commercial purposes without the payment of any royalty to you, and that such license will survive the termination of this Agreement.

TERMINATION: This Agreement becomes effective on the date you accept this Agreement and will continue until terminated as provided for in this Agreement. You may terminate this Agreement voluntarily at any time. Bobsweep may terminate this Agreement at any time if you are in breach of any of its terms and conditions, and may refuse to license the Bobsweep Software or the bObsweep to you after termination. Upon termination by either party, you will immediately return to bObsweep or destroy the Bobsweep Software and the bObsweep and all your copies thereof. Articles 5 and 7 through 17 of this Agreement shall survive such termination. U.S. GOVERNMENT RESTRICTED RIGHTS: The Bobsweep Software and the bObsweep are provided with “RESTRICTED RIGHTS.” Use, duplication or disclosure by the Government is subject to restrictions set forth in FAR52.227-14 and DFAR252.227-7013 et seq. or its successor. Use of the Bobsweep Software or the bObsweep by the Government constitutes acknowledgment of Bobsweep’s rights in them.

NO EXPORT: You may not export the Bobsweep Software or the bObsweep in violation of applicable export laws.

INTERPRETATION PROVISION: The provisions of this Agreement are severable. If any provision of this Agreement is held to be unenforceable, such provision shall be reformed only to the extent necessary to make it enforceable. Any law or regulation which provides that the language of a contract shall be construed against the drafter shall not apply to this Agreement.

INTEGRATION: This Agreement represents the complete agreement concerning the subject matter hereof, and any and all understandings, conversations and communications, proposals, and counterproposals, oral and written (including any draft of this Agreement) are merged into and superseded by this Agreement and shall be of no force or effect, except as expressly provided herein. No such understandings, conversations, communications, proposals, counterproposals or drafts shall be

referred to in any proceeding concerning this Agreement. Further, no understanding contained in this Agreement shall be modified, altered or amended, except by a writing signed by the party against whom enforcement is sought.

ARBITRATION: All disputes relating to this Agreement (excepting any dispute relating to intellectual property rights) shall be subject to final and binding arbitration, with the losing party paying all costs of arbitration. Any arbitration relating to this Agreement shall be held in California, under the auspices of an arbiter selected by Bobsweep. Any litigation relating to this Agreement shall be subject to exclusive venue and jurisdiction in the federal and state courts of California, with the losing party responsible for costs, including without limitation, court costs and reasonable attorneys fees and expenses.

APPLICABLE LAWS: Any claim arising under or relating to this Agreement shall be governed by the internal substantive laws of the Commonwealth of California, without regard to its principles of conflict of laws. The application of the United Nations Convention on Contracts for the International Sale of Goods is expressly excluded.



Download & Connect



App Store



Google Play

bObsweep

