

# CHARLOTTE

## OWNER'S MANUAL

# Table of Contents

1

Important Safety  
Instructions

2

What Comes in the  
Box?

3

Anatomy

5

Who is Charlotte

6

Your Bot's First  
Clean

8

The bObsweep  
App

8

Troubleshooting

9

Maintenance  
and Storage

12

Accessories

14

End User License  
Agreement

## Important Safety Instructions

- Power your bot (Charlotte) OFF and remove it from a power source when you are not using it and before conducting maintenance.
- Charlotte is not intended for use by persons (including children) with reduced physical or mental capabilities, or lack of experience and knowledge, unless under the close supervision of a person responsible for their safety.
- Leaks from the battery cells can occur under extreme usage or temperature conditions. If the liquid gets on the skin, wash quickly with water. If the liquid gets into the eyes, flush them immediately with clean water for a minimum of 10 minutes, and seek medical attention.
- Charlotte is composed of electronic components that in rare and unintended cases can cause hazards of heating, fire, and other malfunctions. Furthermore, because Charlotte is capable of autonomous movement, its use poses the risk of collision with property, pets, and persons. Unintended removal of articles — such as small valuables, wires, jewelry, or hair of persons or pets lying on the floor — may also occur.
- If Charlotte or its charging station has been damaged in any way, do not operate them. Contact our support team for further assistance.
- Do not handle Charlotte or the charging station with wet hands; use only on dry surfaces.
- Do not pull or carry the charging station by the cord, close a door on the cord, or pull the cord around sharp edges or corners. Keep the cord away from heated surfaces. To unplug the cord, grasp the plug, not the cord.
- Do not expose Charlotte to direct sun light or infrared light.
- Do not let Charlotte drop.
- For your safety, do not insert tools, fingers, or other items into Charlotte or disassemble it.
- Do not attempt to open the charging station. Repairs on the station should only be carried out by our qualified technicians.
- With the exception of the mop attachment, do not immerse any part of Charlotte into water or other liquids.
- Do not mutilate or incinerate the battery, as it will explode at high temperatures.
- Do not use Charlotte outdoors.
- Do not store Charlotte in a car. Always follow storage instructions in this manual.
- Do not expose Charlotte or its charging station to temperatures higher than 113° F (45° C), moisture, or humidity.
- Do not dispose of Charlotte's battery in fire. Old batteries should be recycled safely through your local recycler.
- Do not let Charlotte pick up anything that is burning or smoking, such as cigarettes, matches, or hot ashes.
- Only use Charlotte's own adaptor to charge it. Do not use a broken or damaged adapter.
- Do not let Charlotte pick inflammable items, chemicals, or other out of ordinary items.
- If Charlotte's vacuum is jammed remove the obstacle completely before reusing it.

## Declaration of Conformity

This device complies with Part 15 of the FCC rules. Operation is subject to the following two conditions: (1) this device may not cause harmful interference, and (2) this device must accept any interference received, including interference that may cause undesired operation. The manufacturer is not responsible for any radio or TV interference caused by unauthorized modifications or changes to this equipment. Such modifications or changes could void the user's authority to operate the equipment.

This equipment has been tested and found to comply with the limits for a Class B digital device, pursuant to part 15 of the FCC Rules. These limits are designed to provide reasonable protection against harmful interference in a residential installation. This equipment generates, uses, and can radiate radio frequency energy and, if not installed and used in accordance with the instructions, may cause harmful interference to radio communications. However, there is no guarantee that interference will not occur in a particular installation. If this equipment does cause harmful interference to radio or television reception, which can be determined by turning the equipment off and on, the user is encouraged to try to correct the interference by one or more of the following measures:

- Reorient or relocate the receiving antenna.
- Increase the separation between the equipment and receiver.
- Connect the equipment to an outlet on a circuit different from that to which the receiver is connected.
- Consult the dealer or an experienced radio/TV technician for help.

## Warranty

Every Charlotte purchased from an authorized seller comes with our warranty coverage:

- 30-Day Money Back Guarantee
- 1-Year Standard Warranty
- 5-Year Subsidized Repair Plan
- Lifetime of Customer Service

To claim your warranty, register Charlotte at [www.bobsweep.com/warranties](http://www.bobsweep.com/warranties).

## Contact Us

If you have any questions or concerns, please contact our helpful support team at [support@bobsweep.com](mailto:support@bobsweep.com) or 1-888-549-8847.

Business Hours: Monday – Friday, 9 a.m. – 5 p.m. Pacific Time

# What Comes in Charlotte's Box?

Charlotte, Your Intelligent Floor Cleaner **1**

Charging Station **2**

Charging Adapter **3**

Mop Attachment and Mopping Cloth **4**

Cleaning Tool **5**

Water Reservoir Filters (4) **6**

Side Brush (2) **7**

Owner's Manual **8**

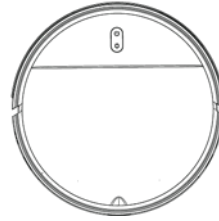

**1**

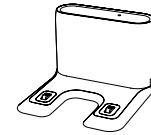

**2**

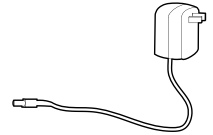

**3**

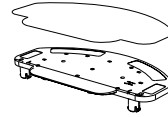

**4**



**5**



**6**

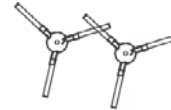

**7**



**8**

# Anatomy

## Top View

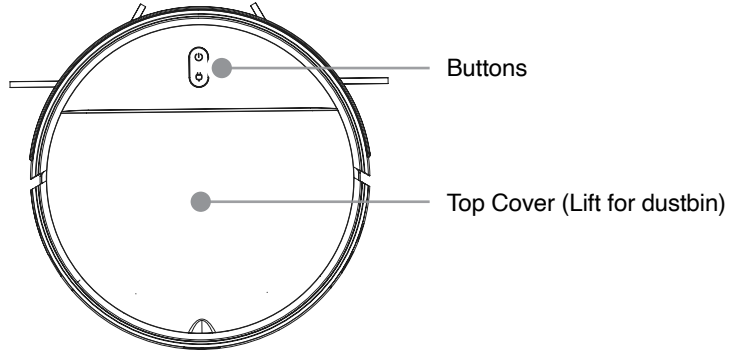

## Bottom View

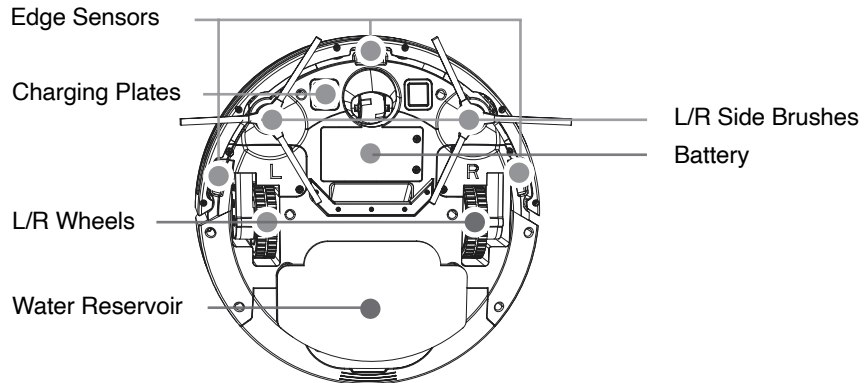

# Anatomy

## Buttons and Indicators

- Power/GO Button**
  - Short Press** - Start/Pause
  - Long Press** - Power ON/OFF
- Charge Button**
  - Short Press** - Charge/Stop
  - Long Press** - Initiate Wi-Fi search

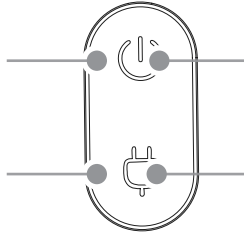

### Power Indicator

- OFF** - Powered OFF / Standby
- Solid Green** - Powered ON and all is good!
- Pulsing Green** - Searching for Wi-Fi
- Pulsing Red** - Trouble detected (includes low battery)  
Charge Charlotte, and check the App

### Charge Indicator

- Solid Yellow** - Finding station
- Solid Red** - Finding station, critically low battery
- Pulsing Green** - Charging
- Solid Green** - Charged

## Dustbin

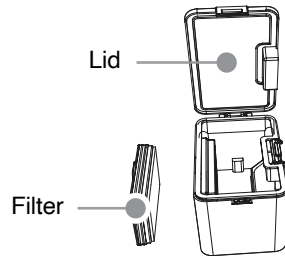

## Charging Station

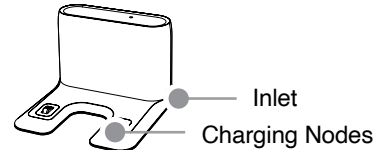

## Who is Charlotte

Charlotte is an autonomous robotic vacuum cleaner, at your service! Connect Charlotte to Wi-Fi and use the bObsweep app to schedule a cleaning for Charlotte.

### Charlotte's Cleaning Behavior

Charlotte's cleaning pattern may look quite different from the way a human would clean: it may spin in a gradually widening circle, follow along walls, or zigzag across a small area. Sometimes it may seem to be ignoring some spaces or spending too much time on others — but don't worry! Charlotte will efficiently clean your home within the course of a full cycle — just check the dustbin for the evidence!

It is best to let Charlotte work in its own way, even if its movements appear odd. Moving it around, manipulating its movements, or picking it up may confuse Charlotte and disrupt its cycle.

### Charlotte's Challenges

#### Unique Furniture

Charlotte is designed to maneuver around furniture of most shapes and sizes, but certain configurations may confuse it temporarily. Charlotte may sometimes find it difficult to clean under chairs with narrow legs, or furniture that is too low for its bumper sensors to detect.

Specialty furniture, such as desk chairs with wheels or stools with circular bases, may also confuse it for a moment — but don't worry, Charlotte usually finds its way around with time.



#### Inclines

Sometimes Charlotte will attempt to drive up angled surfaces and get stuck for a few minutes before deciding to clean somewhere else. This is because Charlotte wants to cover every spot in your home and will try its hardest to overcome any obstacle!

As long as Charlotte does not indicate on its screen that there is a problem, let it find its own way around your home and continue cleaning. Take note of the areas Charlotte finds the most challenging, and if possible spread or adjust some of your furniture accordingly.

# Charlotte's First Clean

## Before Starting

Remove the protective pieces from Charlotte's bumper and charging station.

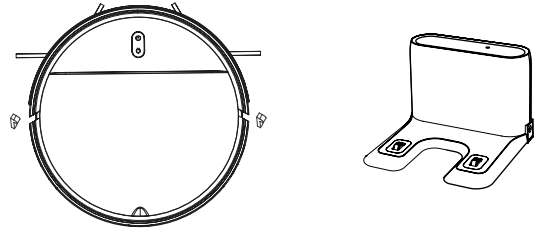

## Step 1: Install Side Brushes

Install Charlotte's side brushes to help it reach the corners and edges of rooms. Place the left (L) and right (R) side brush over the empty socket on Charlotte. Press down to lock onto Charlotte.

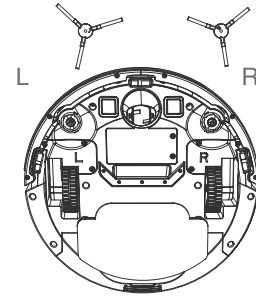

## Step 2: Power Charlotte ON

Press and hold the Power Button on Charlotte until the power indicator lights up.

Press and hold the Power button to power Charlotte ON.

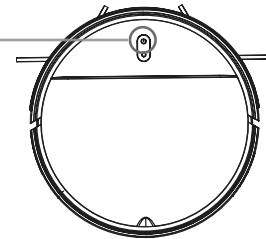



# Charlotte's First Clean

## Step 3: Charge Charlotte

Plug in the charging station, Place it on a hard, flat surface, away from edges and stairs, with plenty of room around it.

To charge Charlotte manually, place it on its station making sure the charging plates on Charlotte align with the charging nodes on the charging station.

Once connected to Wi-Fi, you can charge Charlotte using the bObsweep App.

## Charging Indicator

While charging, Charlotte's charge indicator pulses. When fully charged, the charging indicator shines green. Allow Charlotte to charge completely overnight before its first clean.

## Step 4: Download the bObsweep App

Connect Charlotte to Wi-Fi to gain access to its full suite of features. Download the bObsweep App on your mobile phone, create your account, and follow App instructions to add Charlotte to your app and connect it to Wi-Fi.

## Step 5: Let Charlotte Sweep!

Charlotte is now ready to sweep! Clear away any clutter or wires and press Start on the bObsweep app, or the power button on Charlotte.

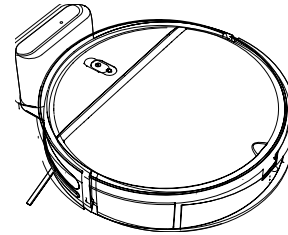
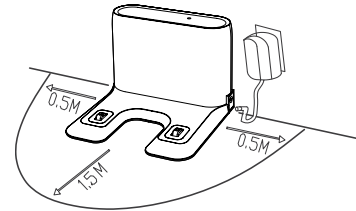

### Standby Mode

When Charlotte is left idle off its charging station for more than 10 minutes, it will enter Standby Mode to preserve its battery. In this mode Charlotte's power indicator turns off. Press the Power Button on Charlotte to wake it up.

## The bObsweep App

To connect Charlotte to your home's 2.4GHz Wi-Fi network:

- 1- Charge Charlotte overnight, and make sure it's powered ON.
- 2- Remove Charlotte from the Charging Station.
- 3- Go to your phone's Wi-Fi settings and connect your phone to a 2.4GHz Wi-Fi Network. Write down your Wi-Fi network's name and password.
- 4- Download the bObsweep mobile app on your phone and sign up to create your account.
- 5- On the HOME page of the app, add a model and select Charlotte from the list of products. Give your bot a nickname, and continue to connect to the 2.4 GHz Wi-Fi network by inputting your Wi-Fi password from step 3.
- 6- Follow step by step instructions on the app to continue connecting Charlotte to Wi-Fi.



App Store



Google Play

## App Controls



Home

### Home

Add multiple Bots, and access digital versions of Quick Start Guide and Owner's Manual on the Home page of the bObsweep app.



Control

### Control

Send Charlotte to clean or charge, on the Control page of the bObsweep app.



Shop

### Shop

Shop for parts, accessories, and extended warranty coverage plans on the Shop page of the bObsweep app.

## Troubleshooting

Whenever Charlotte detects a trouble, it will stop and the power indicator will pulse red. Check the bObsweep app for trouble details.

## Maintenance

Part	Maintenance Frequency	Replacement Frequency
Dustbin	Daily	
Filter	Weekly	Every 6 months
Brushes	Weekly	Every 12 months
Sensors	Weekly	
Front Wheel	Weekly	
Battery		Every 24 months

### Quick Tips:

Clear debris out of nooks and crannies around the brushes and wheels.

Use tweezers to remove congestion from the side brushes and their compartments on Charlotte.

Use scissors or cleaning tool to cut hair wrapped around the brushes.

## Storing Charlotte

If you are not using Charlotte for an extended period of time (over 2 weeks), power it OFF, remove its battery, and unplug its charging station. Store everything in a dry room, away from direct sunlight or extreme temperature.

## Maintenance

### Dustbin and Filters

1. Lift the top cover and remove the dustbin.

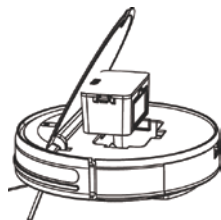

2. Open the dustbin and dump its contents.

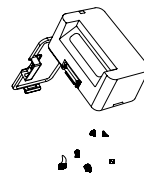

3. Remove the filter cartridge and dust the filter.

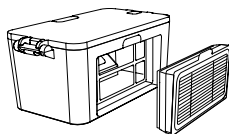

4. Wash or wipe the dustbin, and air dry all parts completely before putting the dustbin back together.

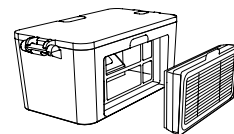

### Brushes

1. Pull up to remove the side brushes.

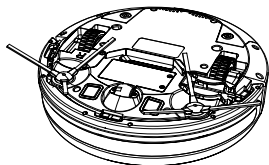

3. Replace the side brushes.

2. Remove debris from the brushes and brush sockets.

## Maintenance

### Sensors

Use a soft cotton cloth to wipe the sensors around Charlotte's bumpers, edge, and wall sensors.

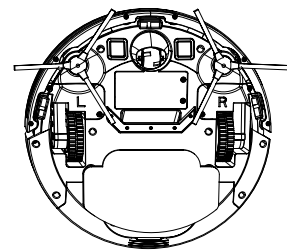

### Front Wheel

Clean the wheel and all its components, including the assembly and wheel socket.

### Charging Nodes

Wipe the charging plates on Charlotte and the charging nodes on its station.

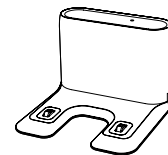

### Battery

Power OFF Charlotte before opening the battery compartment. Use a Phillips head screwdriver to open the battery compartment.

## Accessories

### Wet Mop

#### Important Notes:

- The reservoir should be drained after use to avoid possible water damage.
- Do not let Charlotte sit on the charging station with a wet mopping cloth, or while there's liquid inside the reservoir.
- Use distilled water when operating in hard water areas.

1. Remove the water reservoir.

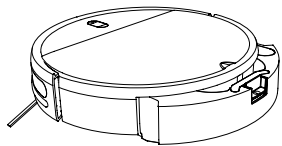

3. Press firmly to close the tab. Replace the water reservoir.

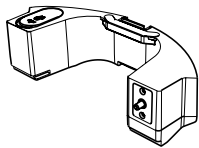

2. Open the tab and fill the reservoir with water.

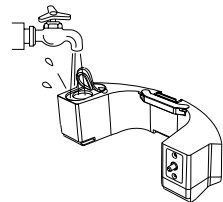

4. Place the mopping cloth on the mop attachment.

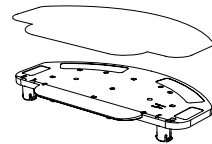

5. Align the prongs of the mop attachment between Charlotte's wheels and press down.

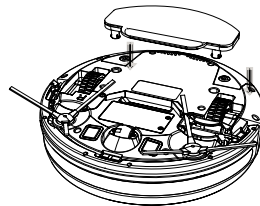

## Accessories

### Wet Mop Maintenance

1. Remove the water reservoir.

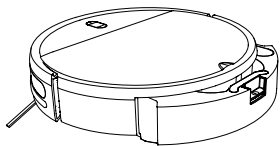

3. Replace the filter.

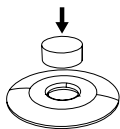

2. Turn it around and remove the rubber piece holding the filter.

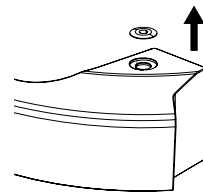

4. Replace the rubber piece into the reservoir.

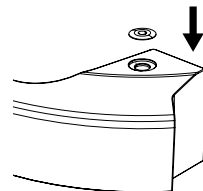

# End User License Agreement

**IMPORTANT - READ BEFORE USING.** Do not use the robot (“bObsweep”) accompanying this license agreement (“Agreement”) until you have carefully read and agreed to the following terms and conditions.

By using the bObsweep, you agree to the terms of this End User License Agreement (“EULA”) and any amendment or addenda accompanying this Agreement. If you do not agree to the terms of this EULA, you may not use the bObsweep. The bObsweep contains an electronic and software interface that allows you to control or modify its behavior, and remotely monitor its sensors.

**THIS IS A LEGAL AGREEMENT. BY ACCESSING AND USING THE PRODUCT AND PRODUCT SOFTWARE, YOU ARE ACCEPTING AND AGREEING TO THIS EULA ON BEHALF OF YOURSELF OR THE ENTITY YOU REPRESENT IN CONNECTION WITH THE ACCESS. YOU REPRESENT AND WARRANT THAT YOU HAVE THE RIGHT, AUTHORITY, AND CAPACITY TO ACCEPT AND AGREE TO THIS EULA ON BEHALF OF YOURSELF OR THE ENTITY YOU REPRESENT. YOU REPRESENT THAT YOU ARE OF SUFFICIENT LEGAL AGE IN YOUR JURISDICTION OR RESIDENCE TO USE OR ACCESS THE PRODUCT SOFTWARE AND TO ENTER INTO THIS EULA. IF YOU DO NOT AGREE WITH ANY OF THE PROVISIONS OF THESE TERMS, YOU SHOULD CEASE USING THE PRODUCT AND PRODUCT SOFTWARE.**

## Terms and Conditions

**LICENSE:** Subject to all of the terms of this Agreement, Bobsweep Inc. (“Bobsweep”) grants to you one (1) revocable, royalty-free, personal, non-exclusive, non-transferable, non-assignable, non-commercial intellectual property license to use the Bobsweep software contained on the bObsweep (“Bobsweep Software”), including the protocol for communicating with the Bobsweep Software, and to use the bObsweep.

**NONCOMMERCIAL LICENSE:** You may use the Bobsweep Software and the bObsweep only for personal, non-commercial, educational, and research purposes. The Bobsweep Software and the bObsweep may not be used for any other purpose, whether “for profit” or “not for profit.” Any work performed or produced using the bObsweep, including any software that you create for your bObsweep (“Your Software”), cannot be performed or produced for the benefit of other parties for a fee, compensation, or any other reimbursement or remuneration. A separate license is required for each additional use and/or individual user in all other cases. If you are an entity, Bobsweep grants you the right to designate one individual within your organization to have the sole right to use the Bobsweep Software and the bObsweep in the manner provided above.

**RESTRICTIONS:** You agree not to: (i) use or copy the Bobsweep Software or the bObsweep except as provided in this Agreement; (ii) rent or lease the Bobsweep Software or the bObsweep to any third party; (iii) assign this Agreement or transfer the Bobsweep Software or the bObsweep except as provided in this Agreement; (iv) modify, adapt, or translate the Bobsweep Software or the bObsweep in whole or in part except as expressly provided in this Agreement; (v) reverse engineer, reverse compile, or disassemble the Bobsweep Software or the bObsweep; or (vi) distribute, sublicense or transfer the source code form of Your Software and derivatives thereof to any third party except as provided in this Agreement.

**YOUR SOFTWARE :** Your Software is also subject to the following limitations: You (i) shall be solely responsible for any update or support obligation or other liability which may arise from your use or distribution, (ii) shall not make any statement that Your Software is “certified,” or that its performance is guaranteed, by Bobsweep, (iii) shall not use Bobsweep’s name or trademarks, (iv) shall prohibit disassembly and reverse engineering of the Bobsweep Software and the bObsweep, (v) shall not publish reviews of Bobsweep products designated as beta without written permission from Bobsweep, and (vi) shall indemnify, hold harmless, and defend Bobsweep and its suppliers from and against any claims or lawsuits, including attorney’s fees, that arise or result from Your Software, including your use and your distribution.

**TITLE:** Title to the Bobsweep Software remains with bObsweep or its suppliers. The Bobsweep Software is licensed, not sold. Except as expressly provided herein, Bobsweep does not grant any express or implied right to you under Bobsweep patents, copyrights, trademarks, or trade secret information. You will not remove any copyright or patent notice from the Bobsweep Software or the bObsweep.

**ONE-TIME TRANSFER:** The initial user of the Bobsweep Software and the bObsweep may make a one-time permanent transfer of this Agreement, the Bobsweep Software, and the bObsweep to another end user, provided that the initial user retains no copies of the Bobsweep Software and the bObsweep. This transfer must include the Bobsweep Software, the bObsweep, and all of the materials accompanying the bObsweep (including all component parts and printed materials, any upgrades, and this End User License Agreement document). The transfer may not be an indirect transfer, such as a consignment. Prior to the transfer, the end user receiving the Bobsweep Software and the bObsweep must agree to all the terms of this Agreement.

**NO WARRANTY AND LIMITED REPLACEMENT: EXCEPT AS STATED IN THE LIMITED WARRANTY TO THE ORIGINAL PURCHASER, THE BOBSWEEP SOFTWARE AND THE BOBSWEEP ARE PROVIDED “AS IS” WITH NO WARRANTIES, EXPRESS OR IMPLIED, INCLUDING BUT NOT LIMITED TO ANY IMPLIED WARRANTY OF MERCHANTABILITY, FITNESS FOR A PARTICULAR PURPOSE, NON-INFRINGEMENT OF INTELLECTUAL PROPERTY RIGHTS, OR ANY WARRANTY OTHERWISE ARISING OUT OF ANY PROPOSAL, SPECIFICATION, OR SAMPLE. NO ORAL OR WRITTEN INFORMATION OR ADVICE GIVEN BY BOBSWEEP OR ITS AGENTS SHALL CREATE A WARRANTY.**

If the Bobsweep Software or the bObsweep is found to be defective in material or workmanship under normal use for a period of one (1) year from the date of receipt, Bobsweep’s entire liability and your exclusive remedy shall be the replacement of the Bobsweep Software or the bObsweep. This offer is void if the defect results from accident, abuse, misapplication, or software that you developed for your bObsweep. Any updates or supplements to the Bobsweep Software or the bObsweep provided to you after the expiration of the one (1) year period are not covered by any warranty or condition, express, implied or statutory.



SOME JURISDICTIONS DO NOT ALLOW THE EXCLUSION OF IMPLIED WARRANTIES, SO THE ABOVE EXCLUSION MAY NOT APPLY TO YOU. LIMITATION OF LIABILITY: THE ABOVE REPLACEMENT PROVISION IS THE ONLY WARRANTY OF ANY KIND. BOBSWEEP OFFERS NO OTHER WARRANTY EITHER EXPRESS OR IMPLIED INCLUDING THOSE OF MERCHANTABILITY, NON INFRINGEMENT OF THIRD- PARTY INTELLECTUAL PROPERTY OR FITNESS FOR A PARTICULAR PURPOSE. NEITHER BOBSWEEP NOR ITS SUPPLIERS SHALL BE LIABLE FOR ANY DAMAGES WHATSOEVER (INCLUDING, WITHOUT LIMITATION, VICARIOUS LIABILITY, CONSEQUENTIAL DAMAGES, INCIDENTAL DAMAGES, DAMAGES FOR LOSS OF BUSINESS PROFITS, BUSINESS INTERRUPTION, LOSS OF BUSINESS INFORMATION, OR OTHER LOSS) ARISING OUT OF THE USE OF OR INABILITY TO USE THE BOBSWEEP SOFTWARE, THE BOBSWEEP, OR SOFTWARE THAT YOU DEVELOPED FOR YOUR BOBSWEEP, EVEN IF BOBSWEEP HAS BEEN ADVISED OF THE POSSIBILITY OF SUCH DAMAGES. BECAUSE SOME JURISDICTIONS PROHIBIT THE EXCLUSION OR LIMITATION OF LIABILITY FOR CONSEQUENTIAL OR INCIDENTAL DAMAGES, THE ABOVE LIMITATION MAY NOT APPLY TO YOU UNAUTHORIZED USE: THE BOBSWEEP SOFTWARE AND THE BOBSWEEP ARE NOT DESIGNED, INTENDED, OR AUTHORIZED FOR USE IN ANY AERONAUTICAL, NUCLEAR, MEDICAL, LIFE SAVING OR LIFE SUSTAINING SYSTEMS, OR FOR ANY OTHER APPLICATION IN WHICH THE USE OF THE BOBSWEEP SOFTWARE OR THE BOBSWEEP COULD CREATE A SITUATION WHERE PERSONAL INJURY OR DEATH MAY OCCUR.

Should you use the Bobsweep Software or bObsweep for any such unintended or unauthorized use, you shall indemnify and hold harmless Bobsweep and its officers, subsidiaries and affiliates against all claims, costs, damages, and expenses, and reasonable attorney fees arising out of, directly or indirectly, any claim of product liability, personal injury or death associated with such unintended or unauthorized use, even if such claim alleges that Bobsweep was negligent regarding the design or manufacture of the Bobsweep Software, the bObsweep, or any part or portion thereof.

**USER SUBMISSIONS:** You agree that any material, information or other communication, including all data, images, sounds, text, and other things embodied therein, that you transmit or post to a Bobsweep website or provide to Bobsweep ("Communications") will be considered non-confidential. Bobsweep will have no confidentiality obligations with respect to the Communications. You agree that Bobsweep and its designers will be free to copy, modify, create derivative works, publicly display, disclose, distribute, license and sublicense through multiple tiers of distribution and licensees, incorporate and otherwise use the Communications, including derivative works thereof, for any and all commercial or non-commercial purposes without the payment of any royalty to you, and that such license will survive the termination of this Agreement.

**TERMINATION:** This Agreement becomes effective on the date you accept this Agreement and will continue until terminated as provided for in this Agreement. You may terminate this Agreement voluntarily at any time. Bobsweep may terminate this Agreement at any time if you are in breach of any of its terms and conditions, and may refuse to license the Bobsweep Software or the bObsweep to you after termination. Upon termination by either party, you will immediately return to Bobsweep or destroy the Bobsweep Software and the bObsweep and all your copies thereof. Articles 5 and 7 through 17 of this Agreement shall survive such termination. U.S. GOVERNMENT RESTRICTED RIGHTS: The Bobsweep Software and the bObsweep are provided with "RESTRICTED RIGHTS." Use, duplication or disclosure by the Government is subject to restrictions set forth in FAR52.227-14 and DFAR252.227-7013 et seq. or its successor. Use of the Bobsweep Software or the bObsweep by the Government constitutes acknowledgment of Bobsweep's rights in them.

**NO EXPORT:** You may not export the Bobsweep Software or the bObsweep in violation of applicable export laws.

**INTERPRETATION PROVISION:** The provisions of this Agreement are severable. If any provision of this Agreement is held to be unenforceable, such provision shall be reformed only to the extent necessary to make it enforceable. Any law or regulation which provides that the language of a contract shall be construed against the drafter shall not apply to this Agreement.

**INTEGRATION:** This Agreement represents the complete agreement concerning the subject matter hereof, and any and all understandings, conversations and communications, proposals, and counterproposals, oral and written (including any draft of this Agreement) are merged into and superseded by this Agreement and shall be of no force or effect, except as expressly provided herein. No such understandings, conversations, communications, proposals, counterproposals or drafts shall be referred to in any proceeding concerning this Agreement. Further, no understanding contained in this Agreement shall be modified, altered or amended, except by a writing signed by the party against whom enforcement is sought.

**ARBITRATION:** All disputes relating to this Agreement (excepting any dispute relating to intellectual property rights) shall be subject to final and binding arbitration, with the losing party paying all costs of arbitration. Any arbitration relating to this Agreement shall be held in California, under the auspices of an arbitrator selected by Bobsweep. Any litigation relating to this Agreement shall be subject to exclusive venue and jurisdiction in the federal and state courts of California, with the losing party responsible for costs, including without limitation, court costs and reasonable attorneys fees and expenses.

**APPLICABLE LAWS:** Any claim arising under or relating to this Agreement shall be governed by the internal substantive laws of the Commonwealth of California, without regard to its principles of conflict of laws. The application of the United Nations Convention on Contracts for the International Sale of Goods is expressly excluded.